

SPECIFICATIONS

MODEL NO.	SLTE-7.5-FRD-80
HORSEPOWER	7.5HP
OPERATING PRESSURE (psi)	85-115
AIR DELIVERY (cfm)	22.6
NOISE LEVEL (dB)	64
AIR OUTLET (BALL VALVE)	1/2"
OPERATING VOLTAGE	3 Phase 208-230/460V, 60Hz
DIMENSIONS (L x W x H)	75 x 33 x 49
APPROX. WT (lbs)	TBD

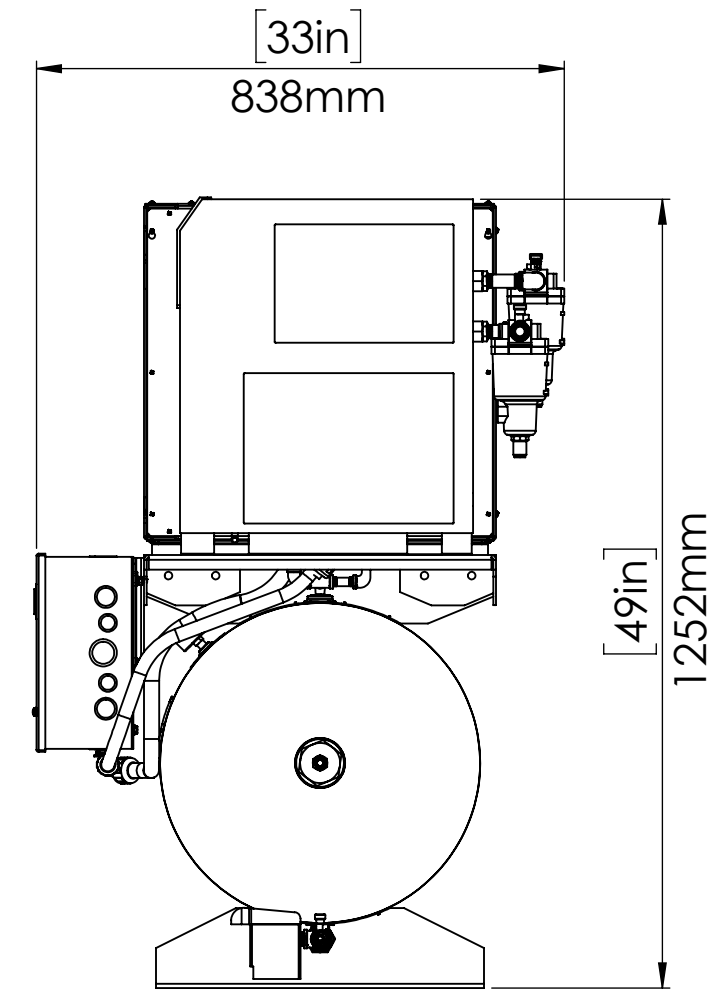

NOTES:

- 1) COMPRESSOR UNIT MUST BE INSTALLED IN A ROOM ON A FLAT FLOOR.
- 2) COMPRESSOR IS AN AIR COOLED UNIT - ROOM TEMPERATURE MUST NOT EXCEED 104 °F. EXHAUST DUCTS OR VENTILATING FAN MUST BE INSTALLED IF ROOM TEMPERATURE EXCEEDS 104 °F.
- 3) PROVIDE ADEQUATE SPACE DURING INSTALLATION FOR NECESSARY MAINTENANCE AND REPAIRS. ALLOW A MINIMUM OF 20" FROM EACH SIDE OF WALL, AND A MINIMUM OF 20" FROM FRONT OF UNIT, AND A MINIMUM OF 24" FROM TOP OF UNIT.
- 4) CARE MUST BE TAKEN TO INSURE COMPRESSOR UNIT DOES NOT INTAKE HOT AIR OR DUST.
- 5) REFER TO INSTRUCTION MANUAL FOR ELECTRIC WIRING DIAGRAM.
- 6) SPEC IS SUBJECT TO CHANGE WITHOUT NOTICE.

**PROPRIETARY AND CONFIDENTIAL**  
 THE INFORMATION CONTAINED IN THIS DRAWING IS THE SOLE PROPERTY OF ANEST IWATA Air Engineering Inc. ANY REPRODUCTION IN PART OR AS A WHOLE WITHOUT THE WRITTEN PERMISSION OF ANEST IWATA Air Engineering Inc. IS PROHIBITED.

UNLESS OTHERWISE SPECIFIED:		NAME	DATE	ANEST IWATA Air Engineering Inc.	
DIMENSIONS ARE IN INCHES		DRAWN	AMM		2/28/20
		CHECKED			
		ENG APPR.			
		MFG APPR.			
INTERPRET GEOMETRIC TOLERANCING PER:		Q.A.			
MATERIAL		COMMENTS:			
ASSY					
FINISH					
NEXT ASSY	USED ON				
APPLICATION		DO NOT SCALE DRAWING			
TITLE:		ANEST IWATA Air Engineering Inc.			
SIZE		DWG. NO.			
C		SLTE-7.5(H)-FRD-80			
SCALE: 1:12		WEIGHT:		SHEET 1 OF 1	