



# INSTRUCTION MANUAL

## ■ OIL-FREE SCROLL TANK MOUNT ENCLOSURE AIR COMPRESSOR

**SLTE-7.5/10/15D/20D**

**SLTE-7.5/10-FM**

Thank you for purchasing our oil-free scroll air compressor.

- Before operation, be sure to read this instruction manual thoroughly for safe and efficient use for a long operating lifetime.
- After reading it, store in a convenient place for immediate and future reading.

Before use, be sure to fill in the blank spaces below for future repair and after service.

MODEL	
SERIAL No.	
Purchased from	
Date of purchase	
Date of use	

# Important information and Safety precautions

## ▪ Important information

Read all important information and safety precautions before use. The operator shall be fully knowledgeable of the requirements stated within this instruction manual, including important warnings, cautions and operation.

**Read manual before performing any maintenance.**



Keep this booklet in an appropriate place for immediate reference.

## • Indications of warnings and cautions

	WARNING	May cause injury or death.
	CAUTION	May result in injury or property damage.

## • Examples of warnings and cautions

	<b>May cause electric shock.</b>
	<b>Do not touch.</b>
	<b>Must be grounded.</b>

\* Supplier is not responsible for any injuries or damages caused by disregard of warnings, operating instruction specifications or maintenance schedules.

<b>Important</b>	Indicates important notices you must observe. They are helpful to achieve top performance and functions of the equipment.
------------------	--

# Important information and Safety precautions

- Safety precautions

## **WARNING**



### **Install in a safe area.**

To prevent a fire or explosion, install in an area free of flammable gases or organic solvents.



### **Never install outdoors.**

To prevent fire or electric shock, never install outdoors.



### **Turn off the main electric source.**

To prevent electric shock or serious injury, always turn off the main electric source before inspecting or wiring the unit.



### **Ask a qualified electrician.**

Only a qualified electrician should perform maintenance on the unit.



### **Be sure to ground.**

Unit must be grounded to prevent electric shock.



### **Never use to compress anything other than air.**

Unit must only be used to compress air.



### **Do not use with respiratory equipment, which could cause serious injury or death.**

# Important information and Safety precautions

---

## **WARNING**



### **Not for use as life support.**

Serious bodily injury and/or death may occur. Unit must only be used to compress air.



### **Do not touch.**

Keep hands and fingers away from fans, pulleys and belts while the power is on.  
Serious injury, including entanglement of fingers or hands can occur.



### **Release pressure.**

Release pressure from unit before conducting maintenance and/or inspection.  
Failure to do so may cause serious injury.



### **Conduct maintenance and inspection.**

Conduct maintenance and inspection according to this manual to prevent unit failure.

# Important information and Safety precautions

## CAUTION



### **Use at ambient temperatures of 36°F to 104°F.**

Drain will freeze at less than 36°F and will cause unit failure.  
Using over 104°F will cause a shorter lifespan or unit damage.



### **Use in an area free of dirt and dust.**

Failure to do so may result in equipment failure.



### **Use in an area free of corrosive gas.**

Failure to do so may result in equipment failure.



### **Only qualified personnel should perform repairs to prevent electric shock or fire.**

If done, it can cause failure.



### **Keep Away.**

Keep away from the compressor while it is operating, and allow it to cool before servicing.  
Failure to do so may result in serious burns and or bodily harm.



### **Never alter the compressor**

Fire and or electric shock may occur if unit is altered and warranty will be void.



### **Use genuine parts**

Be sure to use only genuine parts during maintenance.  
Failure to do so may result in equipment failure.

# Contents

---

Important information and Safety precautions	
■ Important information -----	1
■ Safety precautions -----	2
■ Contents -----	5
Before use	
■ Inspect the product -----	6
Installation	
■ Precaution about installation -----	7
■ Piping -----	8
■ Electrical wiring -----	9
Operation	
■ Before start up -----	11
■ Start-up and operation -----	11
Maintenance	
■ Standard maintenance period -----	13
■ How to carry out maintenance -----	14
Troubleshooting Guide	
■ Compressor -----	15
■ Auto drainer -----	15
Specifications	
■ Compressor specifications -----	16
Appendix	
■ Outer dimensions -----	18
■ Circuit diagram -----	21
Warranty	
■ Warranty and remain -----	23

# Before use

## ▪ Inspect the product

- Inspect the product to be sure you have the model you ordered.

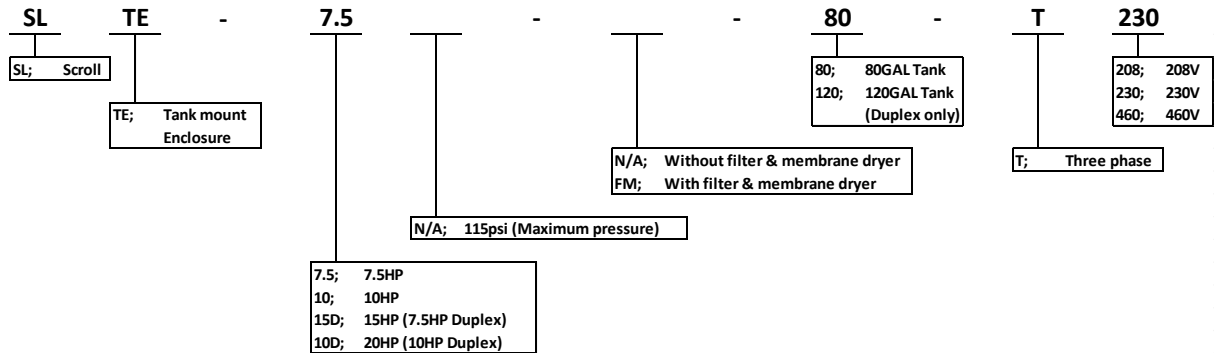

- Check that there is no deformity or damage which occurred during transportation. Any shipping damage must be immediately filed with the freight carrier.
- Check that the following accessories are included.
  - Compressor instruction manual
  - Pump instruction manual
  - Auto drainer instruction manual
  - Membrane dryer instruction manual (-FM unit)
  - 4 rubber mats
  - Wiring schematic

# Installation

---

## ▪ Precautions about installation



### **WARNING!**

Do not use in an area which is exposed to rain, steam or high humidity.

High humidity can cause electric shock or fire.

Do not install in an area with corrosive gas (ammonia, acid, salinity, ozone gas and sulfur dioxide) preventing a shorter lifespan of the unit.



### **WARNING!**

To prevent a fire or explosion, install in an area free of flammable gases or organic solvents.



### **Ambient temperature**

Use at ambient temperatures of 36°F to 104°F.

Using at less than 36°F will cause unit failure or freezing.



### **CAUTION!**

Install this product on a level floor to prevent vibration and noise, causing damage to the unit.



### **CAUTION!**

Install in an area which is free of dust. Dust can cause increased temperature and wear, resulting in a shorter lifespan and/or unit failure.



# Installation

## ▪ Precautions about installation (Continue)

### • Installation space

Secure the space around the compressor for safe inspection and maintenance.

Installation space (inch)	
Above	24
Other Sides	20

### • Ventilation

When using in an enclosed closed room, install a fan for ventilation.

Model	British Thermal Unit (BTU)
SLTE-7.5/SLT-7.5-FM	19,200
SLTE-10/SLT-10-FM	25,600
SLTE-15D	38,400
SLTE-20D	51,200

## ▪ Piping

- Do not use a steel pipe or smaller size than the compressor outlet connection.
- Use the high pressure and heat resistant rubber hose.  
(Pressure resistance; 200psi or more, Heat resistance; 194 °F or more)
- Connect the auto drain as an accessory to the drain plumbing underneath the tank.
- When there is a riser in the piping, be sure to install a drain collector or drain valve.

# Installation

---

- Electrical wiring
  - Precautions about wiring



## **Turn off main electric source.**

Be sure to turn off main electric source before inspection or wiring job.  
If not, it can cause electric shock or serious bodily injury.



## **Ask qualified electrician.**

Ask qualified electrician to perform electric wiring job.  
If not, it can cause electric shock or fire.



## **Be careful about wiring.**

Do not use cable of less than designated size.  
If done, overheat of cable can cause fire.



## **Be sure to ground.**

Be sure to do the grounding on the wiring job.  
If not, it can cause electric shock or fire.

# Installation

- **Wiring**

Be sure to use the fork, pin or blade terminal to firmly connect the electric source to the designated place of the magnetic switch or terminal in the control box. Please refer to the circuit diagram shown in the Appendix.

- 208V-230V/460V, 3PH, 60Hz

Motor Size (HP)	Power (V/PH)	Motor Load (FLA)	Non-time Delay Fuse (A)	Time Delay Fuse (A)	Inverse-time circuit breaker (A)
7.5	208/3	24.2	80	45	70
	230/3	22.0	70	40	60
	460/3	11.0	35	20	30
10	208/3	30.8	100	60	80
	230/3	28.0	90	50	70
	460/3	14.0	45	25	35
15 (7.5 x 2)	208/3	24.2 x 2	150	90	125
	230/3	22.0 x 2	150	80	110
	460/3	11.0 x 2	70	40	60
20 (10 x 2)	208/3	30.8 x 2	200	110	150
	230/3	28.0 x 2	175	100	150
	460/3	14.0 x 2	90	50	70

- Auto drainer

Connect the power cable with a plug to the outlet shown below.

Supply voltage; 230 / 115 / 24 / ...VAC / 24 VDC ± 10%, 50 - 60 Hz

# Operation

## ▪ Before start up:

- Make sure all safety warning labels and instructions have been read and understood before continuing.
- Make sure any shipping materials and brackets are removed.
- Be sure the electric power source has been firmly connected and grounded.
- Make sure all pressure connections are tight.
- Confirm all safety relief valves are correctly installed.
- Check that all fuses and circuit breakers are the proper size.
- Make sure the inlet filter is correctly installed.
- Inspect the drain valve to be sure it is closed.

## ▪ Start-up and operation:

- Turn the electric source breaker on.
- Be sure the auto drainer is energized.
- Turn the pressure switch or both pressure switches on. (SLTE-15D/20D) DO NOT turn both switches on at same time.
- Open the discharge valve completely.
- Confirm the compressor operates without excessive vibration, unusual noises or leaks.
- Close the discharge valve completely.
- If the pressure does not rise on a three phase unit, stop the unit and turn the electric source breaker off. Switch the L1 and L2 connections inside the control box.

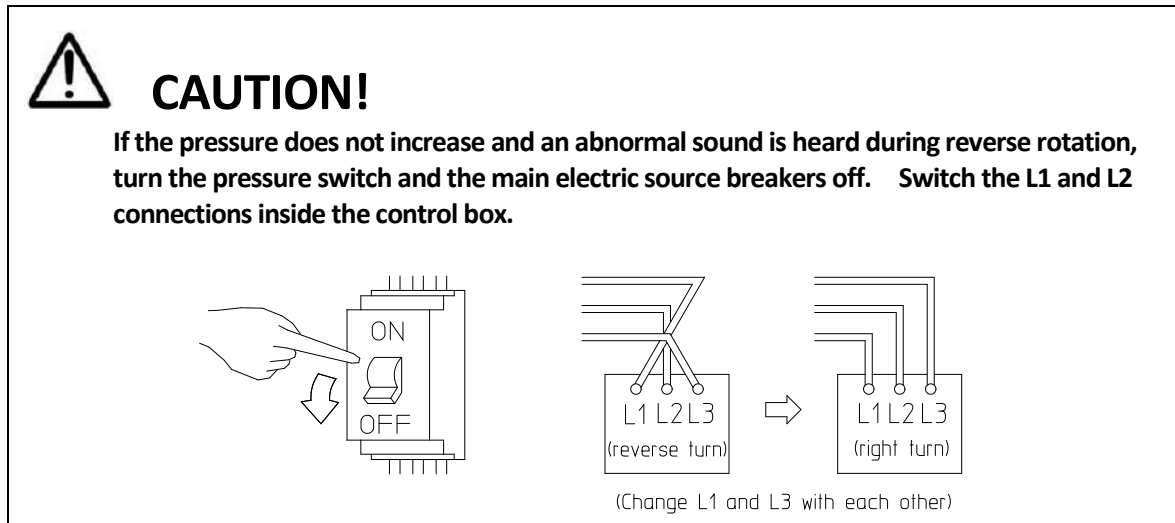

# Operation

---

- Check the discharge pressure. Be sure the compressor **stops** at the setting pressure indicated below.

Model		Cut-out pressure (psi)
SLTE-7.5 SLTE-10 SLTE-7.5-FM SLTE-10-FM		115
SLTE-15D	Lead pump	115
SLTE-20D	Second pump	105

- Check the discharge pressure. Be sure the compressor **starts** at the setting pressure indicated below.

Model		Cut-in pressure (psi)
SLTE-7.5 SLTE-10 SLTE-7.5-FM SLTE-10-FM		85
SLTE-15D	Lead pump	85
SLTE-20D	Second pump	75

# Maintenance

The following maintenance is required at specific intervals. These intervals are based on conditions where the ambient temperature is around 86°F. If your location is warmer or running condition is more severe, maintain within a shorter period. During warmer conditions, shorten the period approximately 30% from our recommendation at every 9°F.

**Standard maintenance period is not our warranty period.**

▪ **Standard maintenance period**

- For 115psi models (SLTE-7.5, SLTE-10, SLTE-15D and SLTE-20D)

**Maintenance is to be done according to operating hours, or period, whichever comes first.**

Item	Details	Maintenance period (every hours or periods)						Remark
		Daily	Every 400 Every 2 months	Every 2,000 yearly	Every 4,000 Every 2 years	Every 8,000 Every 4 years	Every 30,000 Every 15 years	
Drain (Option)	Air receiver	○				○☆		Change as necessary
Noise, vibration	Check	○						
Air intake filter	Clean		○	●				Whenever it is dirty
Safety valve	Check function		○					
V belt	Tension/replace		○ initial only	○		●☆		No slack or loose
Pressure gauge	Check			○				
Ventilation fan	Check function			○				Change as necessary
Magnetic switch	Check or replace				○☆	●☆		
Motor, insulation	Check resistance				○☆			Change as necessary
Motor	Check/replace						●☆	
Pulley	Check					○☆		Change as necessary
Pressure switch	Check function					○☆		Change as necessary
After cooler	Clean					○☆		Change as necessary
O rings	Replace					●☆		Use genuine Parts
Check valve	Check function					●☆		Change as necessary
Air end fan FS-OS fin	Clean					○☆		Whenever it is Dirty
Tip & dust seals Grease up	Replace					●☆		Use genuine Grease
Air end							●☆	

○ Inspect ● Replace ☆ Consult with distributor who sold it to you

\* Air intake filters are not covered under the warranty. You may want to keep extra filters on hand.

- Replace the mainline filter, final filter and membrane dryer. (-FM\*).

The mainline filter and final filters need to be replaced once every two years.

The membrane dryer needs to be replaced once a year.

# Maintenance

▪ **How to carry out maintenance:**

- Intake filter  
Blow dust off the filter with an air gun and replace if it is dirty.
- Safety valve  
Lift up the stem of the safety valve at around maximum pressure and check to see if air blows out.
- Belt tension  
If the V belt makes a slipping sound at the startup, due to decrease of V belt tension, readjust the belt tension or replace it.  
If belt tension is less than the figure in the chart below, adjust belt tension again.  
An exclusive tool is necessary to measure belt tension.  
Ask our distributor to readjust belt tension when needed.

Model	Readjustment standard load / Hz	Readjustment target load / Hz Tolerance $\pm 5$	Replacement new belt target load / Hz Tolerance $\pm 5$
SLTE-7.5 SLTE-7.5-FM SLTE-15D	65	76	84
SLTE-10 SLTE-10-FM SLTE-20D	70	82	90

# Troubleshooting Guide

If you have any problems, please refer to the chart below.

If the (\*) marked items are difficult for you to fix, please contact the shop you purchased it from.

▪ Compressor

Problem	Cause	Corrective action
Compressor unit does not start	Electric source is not ON.	Turn on electric source
	Electric source is not connected correctly.	Connect it correctly
	Pressure switch is in OPEN position	Reduce pressure in air receiver
Power is at supply connection and compressor does not start	Over load relay has tripped	See last entry of Troubleshooting guide
	Wrong or low voltage	Inspect incoming power supply and unit power rating.
	Starter has failed	Inspect, repair or replace contactor assembly *
	Pressure switch has failed	Inspect, repair or replace pressure switch assembly *
	Motor has failed	Inspect, repair or replace motor *
Compressor is running but will not make pressure	Drive belts came off or too loose	Inspect, tighten or replace drive belts *
	Clogged intake filter element	Clean or replace intake filter element
	Discharge air is leaking	Inspect and repair
	Pump has failed	Inspect, repair or replace pump *
	Pump running in the wrong direction	Correct power connections
Excessive noise or vibration	Drive belt has flipped or slipped	Inspect, repair or replace drive belt *
	Motor has failed	Inspect, repair or replace motor*
	Pump has failed	Inspect, repair or replace pump
Compressor running hot	Ambient temperature is high	Be sure not to exceed above 104°F
	Pump running at high pressure	Check tank pressure and pump outlet are not obstructed
	After cooler fins clogged	Clean after cooler
	Clogged intake filter element	Clean or replace intake filter element
Compressor turns on/off rapidly	Receiver tank has high level of water	Drain condensation
	Check valve has failed	Inspect, repair or replace check valve *
	Pressure switch has failed	Inspect, repair or replace pressure switch *
Safety valve blows off	Motor starter contacts welded shut	Inspect, repair or replace motor starter *
	Pressure switch has failed	Inspect, repair or replace pressure switch *
Motor overload has tripped	Pump has failed	Inspect, repair or replace pump *
	Motor has failed	Inspect, repair or replace motor*
	Improper wiring	Inspect and rewire *
	Wrong overload setting	Check setting of overload relay *
	Low voltage	Check incoming power supply

▪ Auto drainer

If there are any problems occurring in the auto drainer, please read the enclosed manual for the auto drainer BEKOMAT31.



# Specifications

## Compressor specifications

- 7.5 / 10HP

Item		SLTE-7.5-80	SLTE-10-80
Operating pressure	psi	85 - 115	
Air delivery (*1)	cfm	22.6	29.7
Tank size	GAL	80	
Noise level (*2)	dB(A)	64	65
Air outlet		NPT 3/4"	
Operating voltage		3Phase, 208-230/460V, 60Hz	
Dimensions (LxWxH) (*3)	In.	64 x 29 x 49	
Approx. mass	Lbs.	580	630

\*1. Air delivery means average discharge air volume at the maximum operating pressure, converted into atmospheric pressure. It is not a warranted figure.

\*2. Noise level is measured in an anechoic room.

\*3. Dimensions are outer dimensions, excluding extruding parts.

Item		SLTE-7.5-FM-80	SLTE-10-FM-80
Operating pressure	psi	85 - 115	
Air delivery (*1)	cfm	19.8	26.9
Tank size	GAL	80	
Noise level (*2)	dB(A)	64	65
Air outlet		NPT 3/4"	
Operating voltage		3Phase, 208-230/460V, 60Hz	
Dimensions (LxWxH) (*3)	In.	64 x 33 x 49	
Approx. mass	Lbs.	595	645

\*1. Air delivery means average discharge air volume at the maximum operating pressure converted into atmospheric pressure. It is not a warranted figure.

\*2. Noise level is measured in an anechoic room.

\*3. Dimensions are outer dimensions excluding extruding parts.

\*4. Main-line filter (AM450C-N06D)

Nominal filtration rating: 0.3µm [Filtration efficiency: 99.9%]

Oil mist density at outlet: Max. 1.0 mg/m<sup>3</sup> (ANR) [≒0.8ppm]

Filter element: AM-EL450

\*5. Membrane dryer (115psi; DM20-53CA-N; including filter, 0.01µm)

This is designed for approximately 44 / 55°F as a dew point and approximately 19.8 / 26.9 cfm as a final discharge flow. If more information is needed, please refer to the instruction manual for the membrane dryer that is enclosed.

# Specifications

- 15 / 20HP

Item		SLTE-15D-120	SLTE-20D-120
Operating pressure	psi	85 - 115 (Lead pump)	
		75 - 105 (Second pump)	
Air delivery (*1)	cfm	45.2	59.4
Tank size	GAL	120	
Noise level (*2)	dB(A)	69	
Air outlet		NPT 1"	
Operating voltage		3Phase, 208-230/460V, 60Hz	
Dimensions (LxWxH) (*3)	In.	70 x 43 x 52	
Approx. mass	Lbs.	1100	1160

\*1. Air delivery means average discharge air volume at the maximum operating pressure, converted into atmospheric pressure. It is not a warranted figure.

\*2. Noise level is measured in an anechoic room.

\*3. Dimensions are outer dimensions, excluding extruding parts.

# Appendix

## Outer dimensions

- SLTE-7.5/10-80

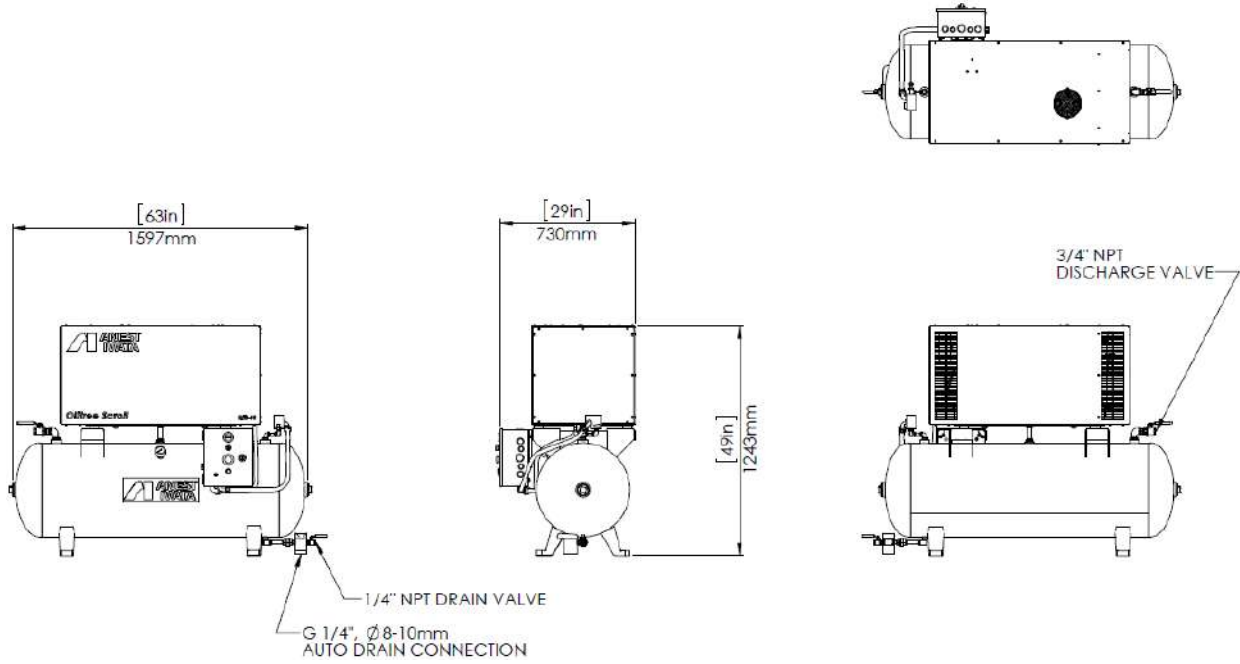

- SLTE-7.5/10-FM-80

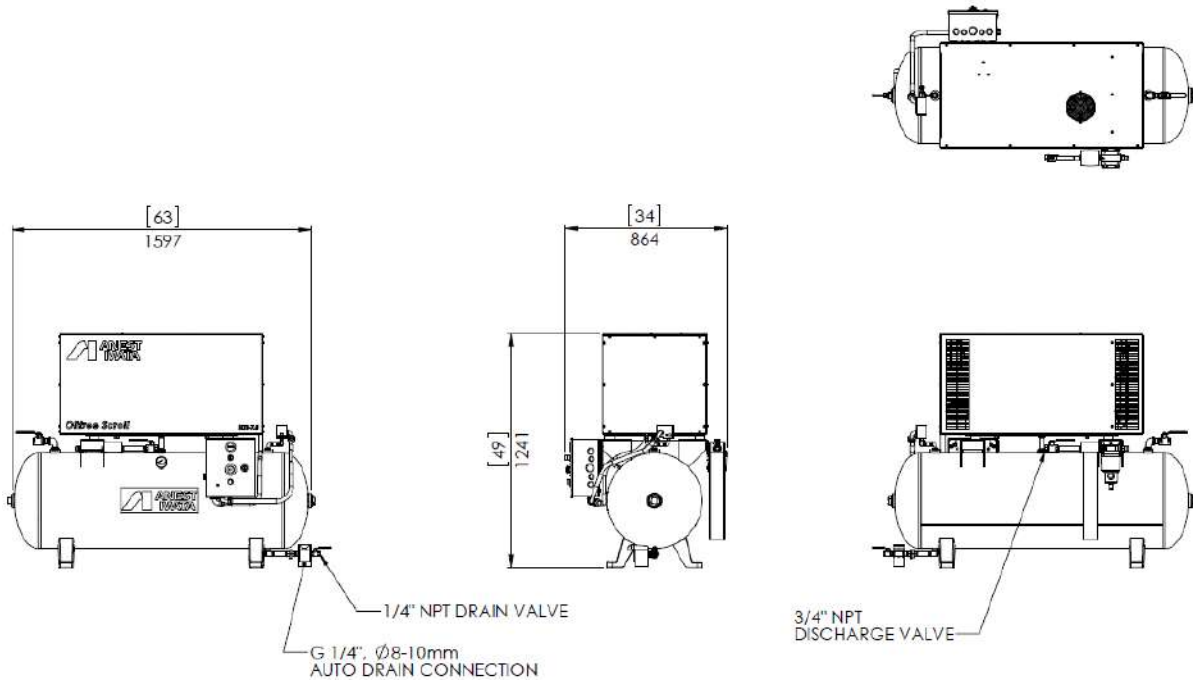

# Appendix

## Outer dimensions

- SLTE-15D/20D-120

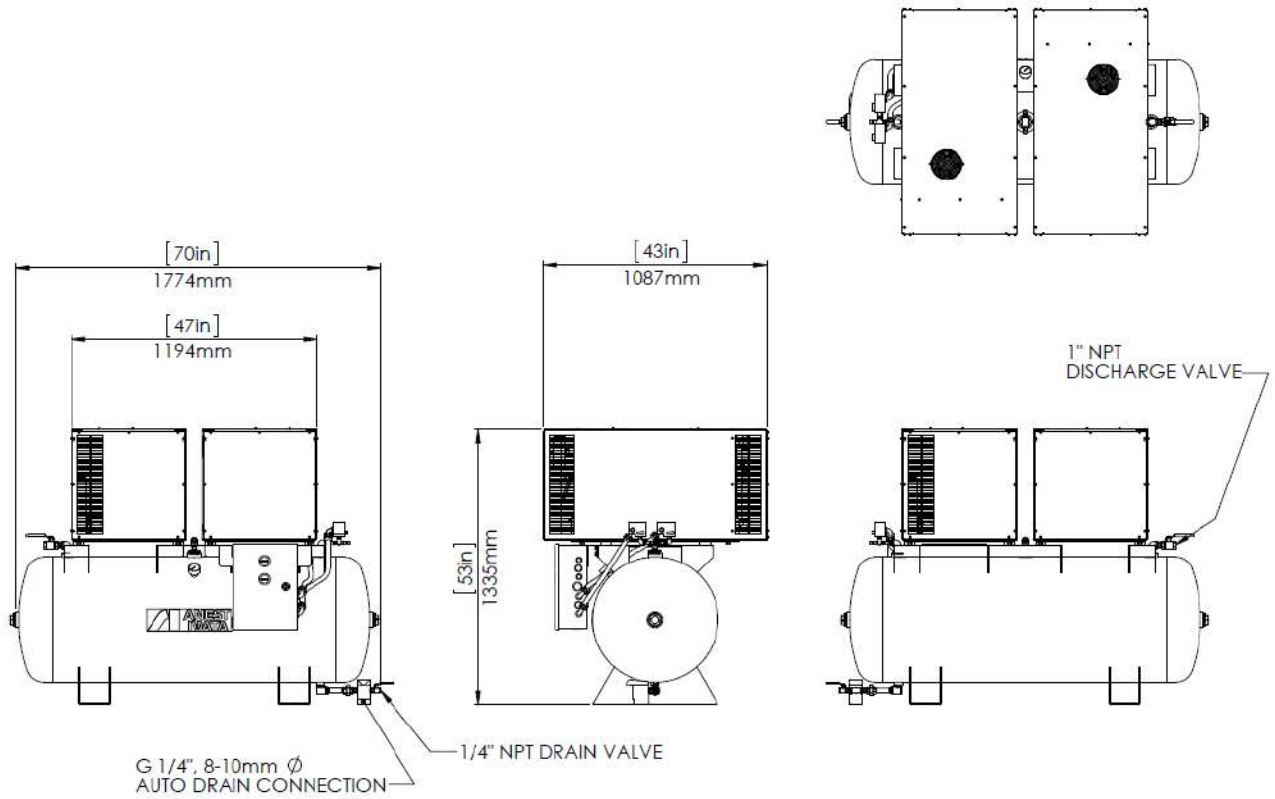

# Appendix

## ▪ Circuit diagram

- SLTE-7.5 / SLTE-10

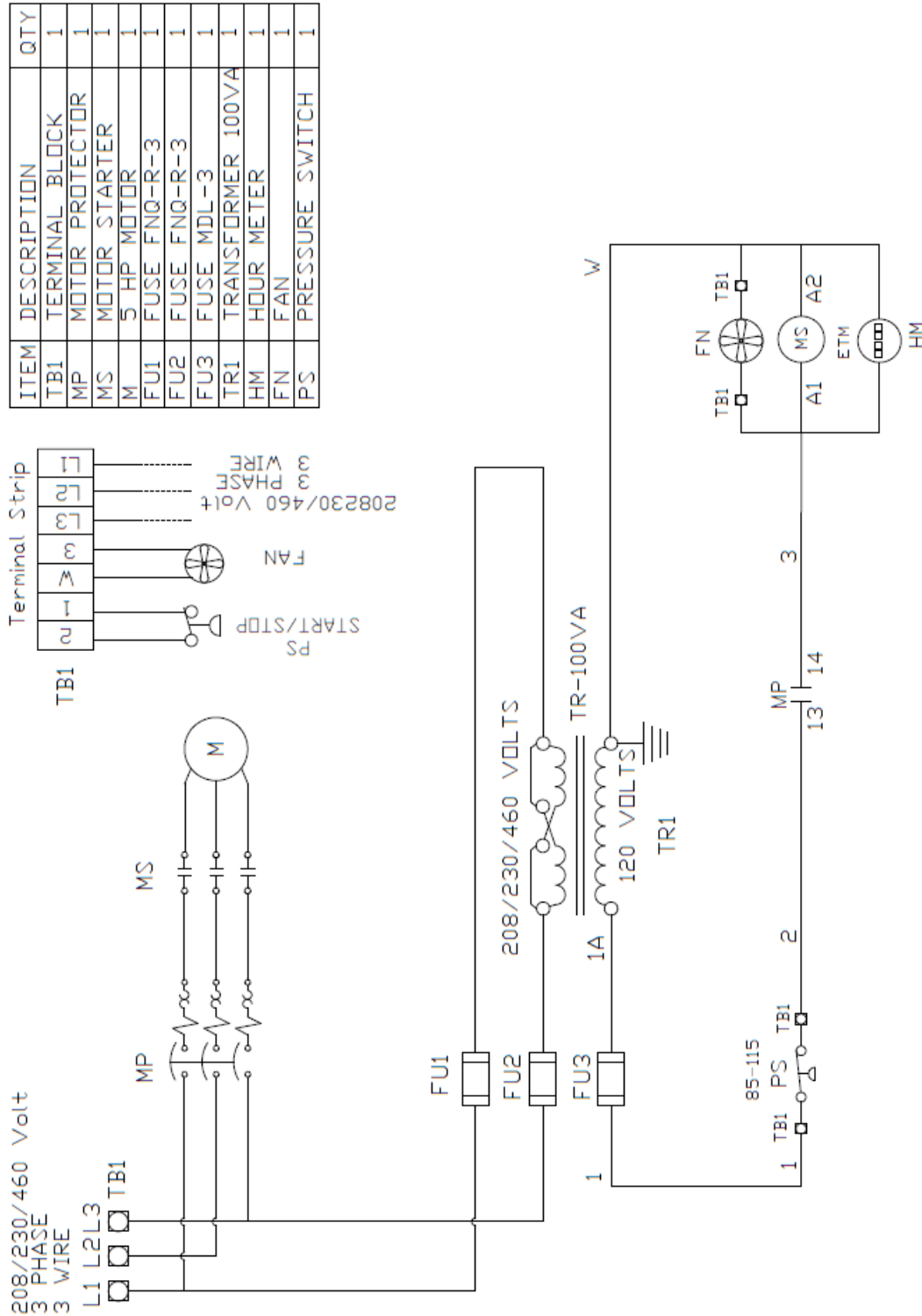

# Appendix

- SLTE-15D / SLTE-20D

ITEM	DESCRIPTION	QTY
TB1	TERMINAL BLOCK	1
MP	MOTOR PROTECTOR	2
MS	MOTOR STARTER	2
M	MOTOR	2
FU1	FUSE FNG-R-3	1
FU2	FUSE FNG-R-3	1
FU3	FUSE FNG-R-3	1
TR1	TRANSFORMER 100VA	1
HM	HOUR METER	2
TDR	TIMER RELAY	1
PS	PRESSURE SWITCH	2
FN	FANS	2

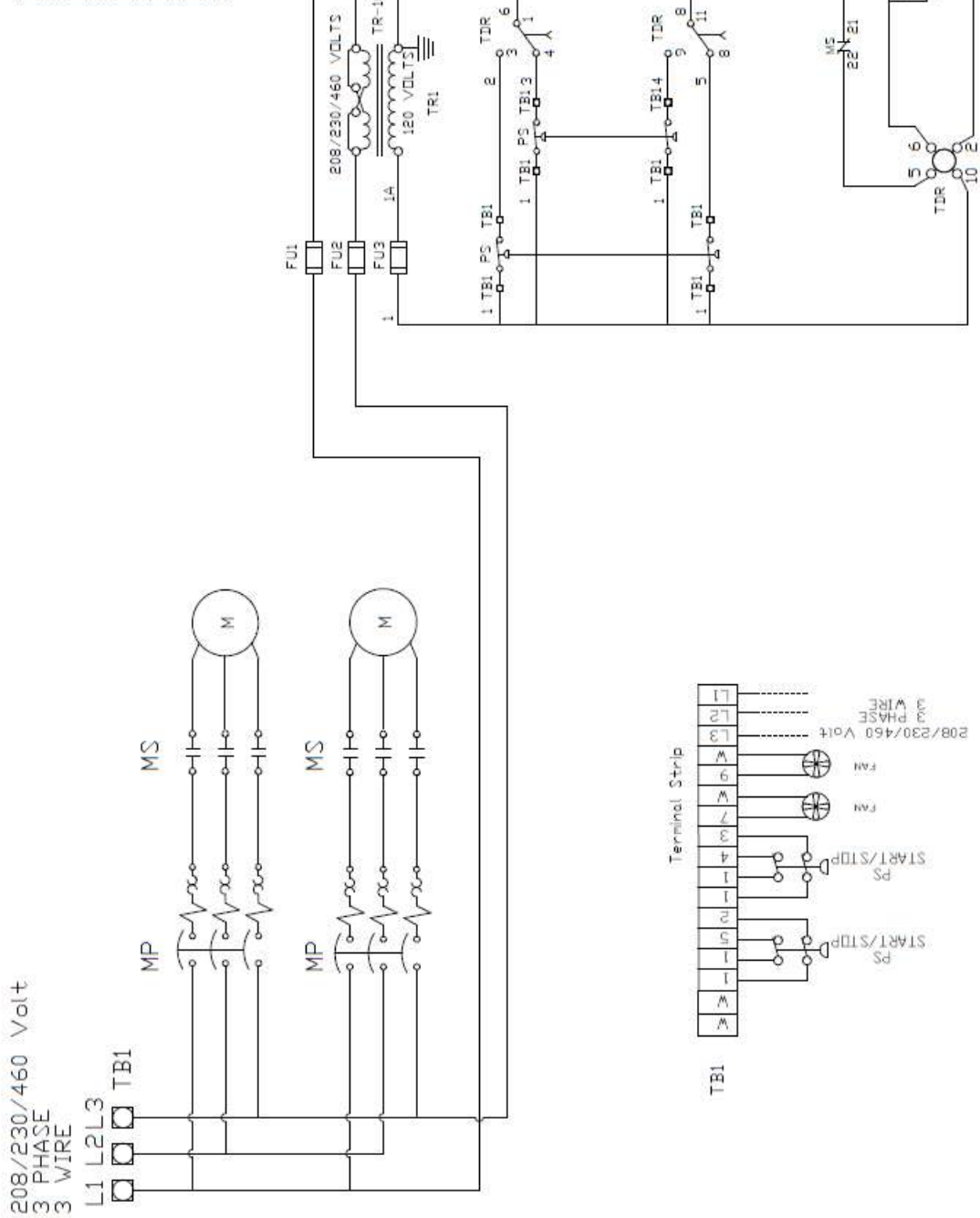

# Warranty

## ▪ Warranty and Remedies

- (a) **General.** Anest Iwata - Air Engineering warrants each Compressor System, Compressor Air-End, or Anest Iwata branded accessory (collectively “products”, individually each a “product”) to be free from defects in material and workmanship (“Defects”) at the date of shipment. EXCEPT AS SET FORTH BELOW, NO OTHER WARRANTY, WHETHER EXPRESS OR IMPLIED, INCLUDING ANY WARRANTY OF MERCHANTABILITY OR FITNESS FOR A PARTICULAR PURPOSE, SHALL EXIST IN CONNECTION WITH THE SALE OR USE OF SUCH PRODUCTS. TO THE EXTENT PERMITTED BY LAW ANY AND ALL IMPLIED WARRANTIES ARE EXCLUDED. All claims under this warranty must be made in writing and delivered to Anest Iwata Air Engineering, or such claim shall be barred. Upon timely receipt of a claim, Anest Iwata Air Engineering shall inspect the product claimed to have a defect, and Anest Iwata Air Engineering shall repair, or, at its option, replace, free of charge, any product which it determines to have had a defect at the time of shipment from Anest Iwata Air Engineering; provided, however, that if circumstances are such as to preclude the remedying of defect by repair or replacement, Anest Iwata Air Engineering shall, upon return of the product, refund to buyer any part of the purchase price of such products paid to Anest Iwata Air Engineering. Freight for the returning products to Anest Iwata Air Engineering for inspection shall be paid by buyer. The warranties and remedies herein are the sole and exclusive remedy for any breach of warranty or for any other claim based on any defect, or non-performance of the products, whether based upon contract, warranty or negligence.
- (b) **Initial period of warranty – Parts and Labor.** Anest Iwata Air Engineering warrants and represents all products shall be free from defects for the first twelve (12) months from the date of shipment by Anest Iwata Air Engineering, or five thousand (5,000) hours of use, whichever occurs first. During such warranty period, Anest Iwata Air Engineering shall be fully liable for all defects in the products (the “product defects”), i.e., all costs of repair or replacement, which may include “in and out” charges, so long as the products are located in the continental United States, and the products are reasonably located and accessible by service personnel for removal. “In and out” charges include the costs of removing a product from buyer’s equipment for repair or replacement.
- (c) **Additional period of Warranty – Parts Only (No Labor).** In addition to the above, Anest Iwata Air Engineering warrants each Anest Iwata branded compressor air-end, shall be free of defects for a period of eighteen months from the date of shipment of product, or 10,000 hours of use, whichever occurs first. Supplier’s repair or replacement of any product shall not extend the period of any warranty of any product. This warranty applies to the exchange of part(s) found to be defective by an authorized Anest Iwata service center only.
- (d) **Coverage.** The above mentioned warranty applies to Anest Iwata Air Engineering manufactured units or systems only.
- (e) **Exceptions.** Notwithstanding anything to the contrary herein, Anest Iwata Air Engineering shall have no warranty obligations with respect to products:
- (i) That have not been installed in accordance with Anest Iwata Air Engineering’s Written specifications and instructions;
  - (ii) That have not been maintained in accordance with Anest Iwata Air Engineering’s written instructions;
  - (iii) that have been materially modified without the prior written approval of Anest Iwata Air Engineering; or
  - (iv) That experience failures resulting from operation, either intentional or otherwise, in excess of rated capacities or in an otherwise improper manner.
- (f) The warranty provided herein shall not apply to: (i) any defects arising from corrosion, abrasion, use of insoluble lubricants, or negligent attendance to or faulty operation of the products; (ii) ordinary wear and tear of the products; or (iii) defects arising from abnormal conditions of temperature, dirt or corrosive matter; (iv) any OEM component which is shipped by Anest Iwata Air Engineering with the original manufacturer’s warranty, which shall be the sole applicable warranty for such component.

**Limitation of liability.** TO THE EXTENT ALLOWABLE UNDER APPLICABLE LAW, NOT WITHSTANDING ANYTHING TO THE CONTRARY HEREIN, UNDER NO CIRCUMSTANCES SHALL ANEST IWATA AIR ENGINEERING BE LIABLE FOR ANY INCIDENTAL, CONSEQUENTIAL, PUNITIVE, SPECULATIVE OR INDIRECT LOSSES OR DAMAGES WHATSOEVER ARISING OUT OF OR IN ANY WAY RELATED TO ANY OF THE PRODUCTS OR GOODS SOLD OR AGREED TO BE SOLD BY POWEREX TO BUYER. TO THE EXTENT ALLOWABLE UNDER APPLICABLE LAW, ANEST IWATA AIR ENGINEERING’S LIABILITY IN ALL EVENTS IS LIMITED TO AND SHALL NOT EXCEED THE PURCHASE PRICE PAID.

**Warranty Disclaimer.** Anest Iwata Air Engineering has made a diligent effort to illustrate and describe the products in this literature accurately; however, such illustrations and descriptions are for the sole purpose of identification, and do not express or imply a warranty that the products are merchantable, or fit for a particular purpose, or that the products will necessarily conform to the illustrations or descriptions.

**Product Suitability.** Many jurisdictions have codes and regulations governing sales, construction, installation, and/or use of products for certain purposes, which may vary from those in neighboring areas. While Anest Iwata Air Engineering attempts to assure that its products comply with such codes, it cannot guarantee compliance, and cannot be responsible for how the product is installed or used. Before purchase and use of a product, please review the product applications, and national and local codes and regulations, and be sure that the product, installation, and use will comply with them.

**Claims.** Claims pertaining to the products, with the exception of warranty claims, must be filed with Anest Iwata Air Engineering within 6 months of the invoice date, or they will not be honored. Prices, discounts, and terms are subject to change without notice or as stipulated in specific product quotations. All agreements are contingent upon strikes, accidents, or other causes beyond our control. All shipments are carefully inspected and counted before leaving the factory. Please inspect carefully any receipt of products noting any discrepancy or damage on the carrier’s freight bill at the time of delivery. Discrepancies or damage which obviously occurred in transit are the carrier’s responsibility and related claims should be made promptly directly to the carrier. Returned products will not be accepted without prior written authorization by Anest Iwata Air Engineering and deductions from invoices for shortage or damage claims will not be allowed. **UNLESS OTHERWISE AGREED TO IN WRITING, THESE TERMS AND CONDITIONS WILL CONTROL IN ANY TRANSACTION WITH ANEST IWATA AIR ENGINEERING** Any different or conflicting terms as may appear on any order form now or later submitted by the buyer. All orders are subject to acceptance by Anest Iwata Air Engineering.

Anest Iwata Air Engineering 5325 Muhlhauser Road, Hamilton, Ohio 45011 USA 800-440-0282



ANEST IWATA AIR ENGINEERING, Inc.

[www.anestiwata.com](http://www.anestiwata.com)

[inquiry@anestiwata.com](mailto:inquiry@anestiwata.com)

Toll Free (800)440-0282

No.SLTE20D-99\_rev2.0