

	SLTE-5-FM-60	SLTE-5H-FM-60
HORSEPOWER	5	5
OPERATING PRESSURE (PSI)	85-115	115-145
AIR DELIVERY (CFM)	13.4	10.9
CONTROL SYSTEM	MULTIPLE UNIT CONTROL - AUTO/START STOP	
NOISE LEVEL (dB A)	61	
AIR OUTLET (BALL VALVE)	1/2" NPT	
OPERATING VOLTAGE	3 PHASE, 208-230/460V, 60 Hz	
DIMENSIONS (L x W x H)	49" x 32" x 48"	
APPROX. WT. (LBS.)	465	

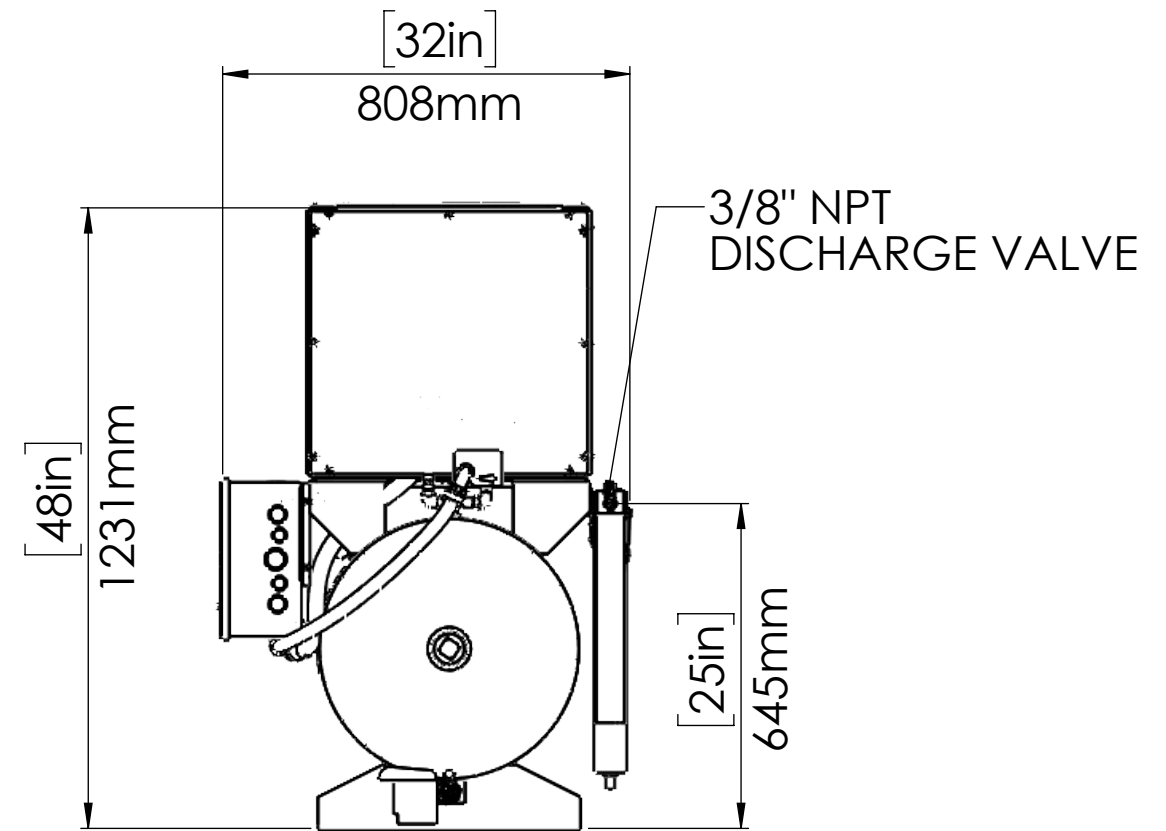
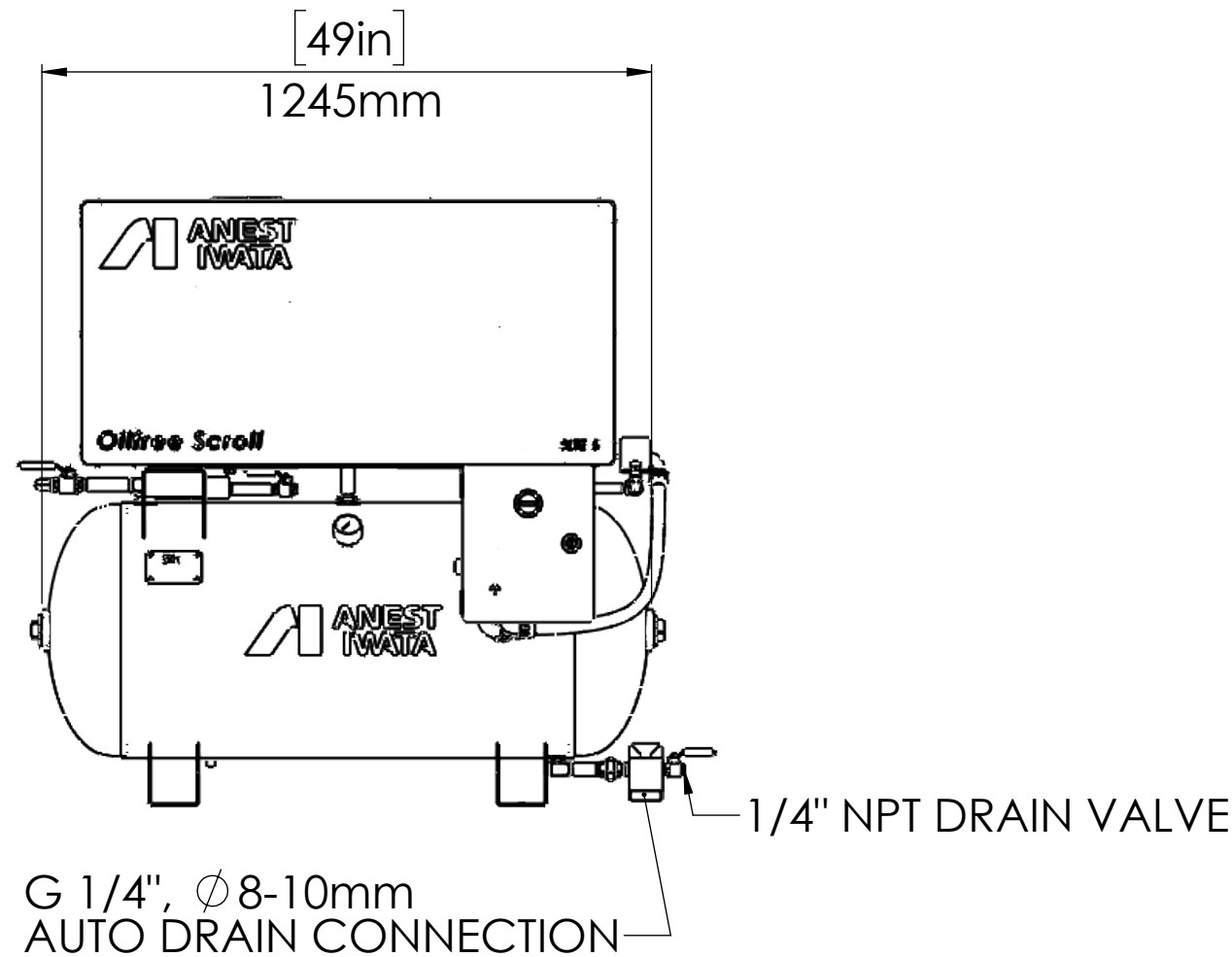

NOTES:

- 1) COMPRESSOR UNIT MUST BE INSTALLED IN A ROOM ON A FLAT FLOOR
- 2) COMPRESSOR IS AN AIR COOLED UNIT - ROOM TEMPERATURE MUST NOT EXCEED 104° F
EXHAUST DUCTS OR VENTILATING FAN MUST BE INSTALLED IF ROOM TEMPERATURE EXCEEDS 104° F
- 3) PROVIDE ADEQUATE SPACE DURING INSTALLATION FOR NECESSARY MAINTENANCE AND REPAIRS
ALLOW A MINIMUM OF 20" ON EACH SIDE AND 24" FROM TOP OF UNIT FROM WALLS
- 4) CARE MUST BE TAKEN TO INSURE COMPRESSOR UNIT DOES NOT INTAKE HOT AIR OR DUST
- 5) REFER TO INSTRUCTION MANUAL FOR ELECTRIC WIRING DIAGRAM
- 6) SPEC IS SUBJECT TO CHANGE WITHOUT NOTICE

PROPRIETARY AND CONFIDENTIAL
THE INFORMATION CONTAINED IN THIS DRAWING IS THE SOLE PROPERTY OF ANEST IWATA. ANY REPRODUCTION IN PART OR AS A WHOLE WITHOUT THE WRITTEN PERMISSION OF ANEST IWATA IS PROHIBITED.

UNLESS OTHERWISE SPECIFIED:		NAME	DATE	ANEST IWATA Air Engineering Inc.
DIMENSIONS ARE SHOWN IN INCHES AND MILLIMETERS	DRAWN	AMM	4/15/20	
	CHECKED	AGH	4/20/20	
	ENG APPR.			
	MFG APPR.			
		Q.A.		TITLE:
		COMMENTS:		SLTE-5(H)-FM-60 OIL FREE SCROLL UNIT TANK MOUNT COMPRESSOR
MATERIAL	ASS'Y	SIZE	DWG. NO.	REV
FINISH		B	SLTE-5(H)-FM-60-R2	2
DO NOT SCALE DRAWING		SCALE: 1:15 WEIGHT:		SHEET 1 OF 1