

	SLTE-3-FM-30	SLTE-3H-FM-30
HORSEPOWER	3	3
OPERATING PRESSURE (PSI)	85-115	115-145
AIR DELIVERY (CFM)	7.0	5.9
CONTROL SYSTEM	MULTIPLE UNIT CONTROL - AUTO/START STOP	
NOISE LEVEL (dB A)	56	
AIR OUTLET (BALL VALVE)	3/8" NPT	
OPERATING VOLTAGE	3 PHASE, 208-230/460V, 60 Hz	
DIMENSIONS (L x W x H)	47" x 32" x 43"	
APPROX. WT. (LBS.)	395	

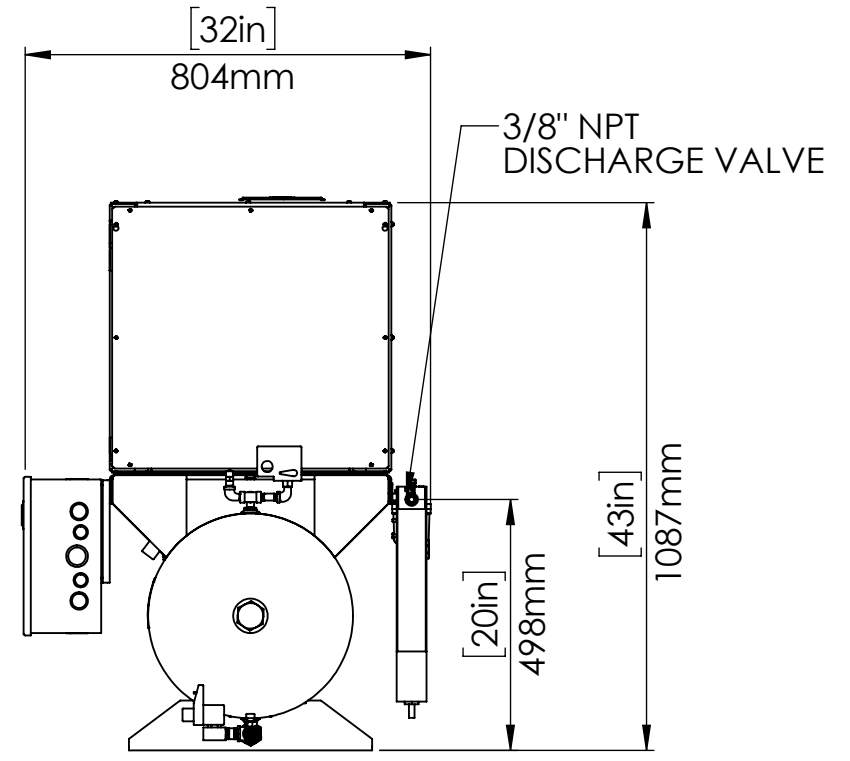
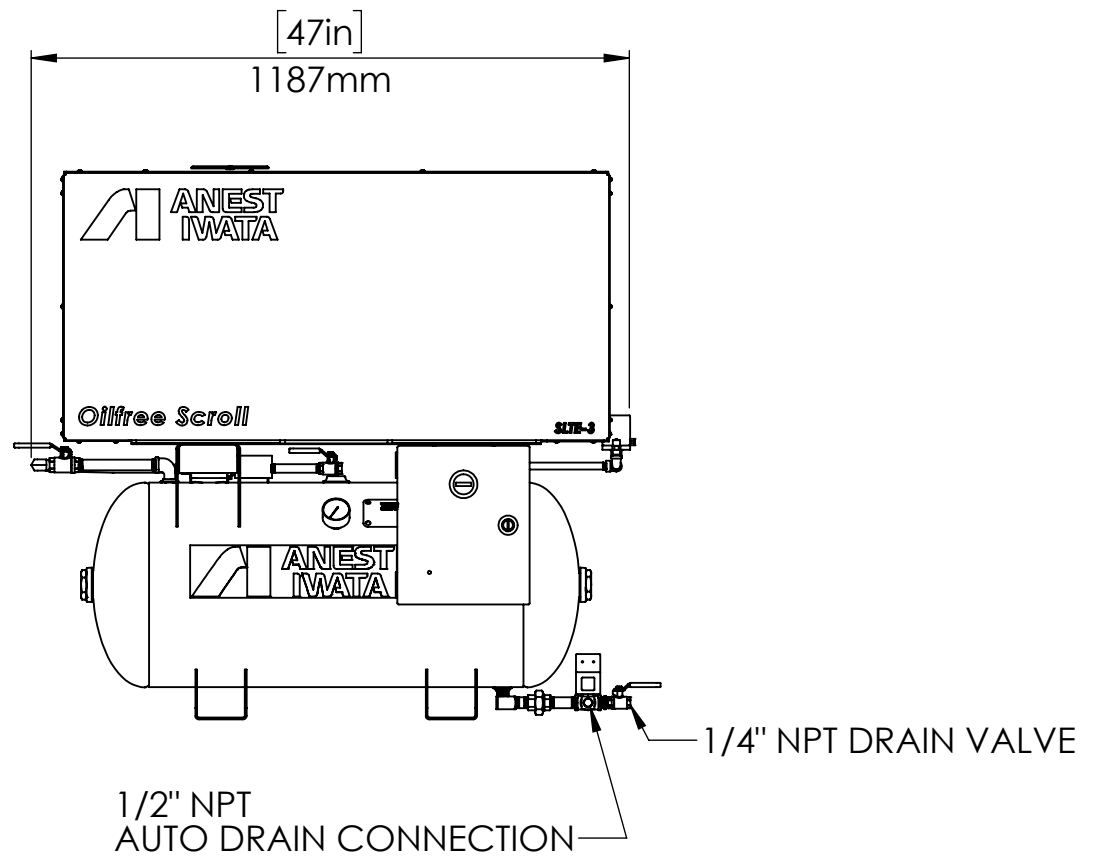

- NOTES:**
- 1) COMPRESSOR UNIT MUST BE INSTALLED IN A ROOM ON A FLAT FLOOR
 - 2) COMPRESSOR IS AN AIR COOLED UNIT - ROOM TEMPERATURE MUST NOT EXCEED 104° F
EXHAUST DUCTS OR VENTILATING FAN MUST BE INSTALLED IF ROOM TEMPERATURE EXCEEDS 104° F
 - 3) PROVIDE ADEQUATE SPACE DURING INSTALLATION FOR NECESSARY MAINTENANCE AND REPAIRS
ALLOW A MINIMUM OF 20" ON EACH SIDE AND 24" FROM TOP OF UNIT FROM WALLS
 - 4) CARE MUST BE TAKEN TO INSURE COMPRESSOR UNIT DOES NOT INTAKE HOT AIR OR DUST
 - 5) REFER TO INSTRUCTION MANUAL FOR ELECTRIC WIRING DIAGRAM
 - 6) SPEC IS SUBJECT TO CHANGE WITHOUT NOTICE

PROPRIETARY AND CONFIDENTIAL
 THE INFORMATION CONTAINED IN THIS DRAWING IS THE SOLE PROPERTY OF ANEST IWATA. ANY REPRODUCTION IN PART OR AS A WHOLE WITHOUT THE WRITTEN PERMISSION OF ANEST IWATA IS PROHIBITED.

UNLESS OTHERWISE SPECIFIED:		NAME	DATE	ANEST IWATA Air Engineering Inc.
DIMENSIONS ARE IN INCHES AND MILLIMETERS	DRAWN	AMM	4/14/20	
	CHECKED	AGH	4/20/20	
	ENG APPR.			
	MFG APPR.			TITLE: SLTE-3(H)-FM-30 OIL-FREE SCROLL UNIT TANK MOUNT COMPRESSOR FILTER MEMBRANE DRYER
	Q.A.			
INTERPRET GEOMETRIC TOLERANCING PER:		COMMENTS:		SIZE DWG. NO. REV B SLTE-3(H)-FM-30-R1 1
MATERIAL ASS'Y				
PART NO.				SCALE: 1:15 WEIGHT: SHEET 1 OF 1
DO NOT SCALE DRAWING				

