

	SLTE-2-FM-30	SLTE-2H-FM-30
HORSEPOWER	2	2
OPERATING PRESSURE (PSI)	85-115	115-145
AIR DELIVERY (CFM)	4.8	4.0
CONTROL SYSTEM	MULTIPLE UNIT CONTROL - AUTO/START STOP	
NOISE LEVEL (dB A)	51	
AIR OUTLET (BALL VALVE)	3/8" NPT	
OPERATING VOLTAGE	1 PHASE, 115/208-230V, 60Hz 3 PHASE, 208-230/460V, 60Hz	
DIMENSIONS (L x W x H)	48" x 29" x 43"	
APPROX. WT. (LBS.)	380	

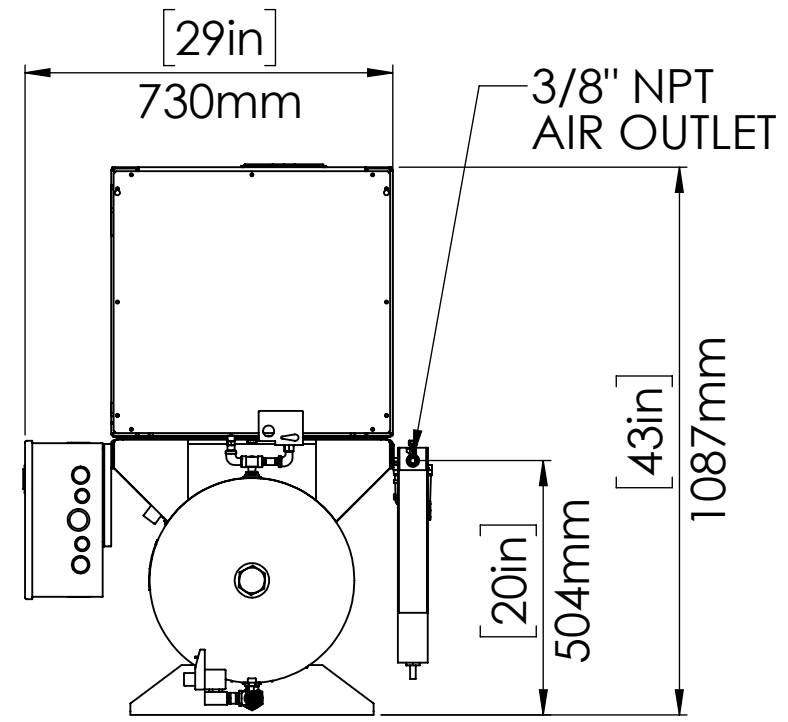
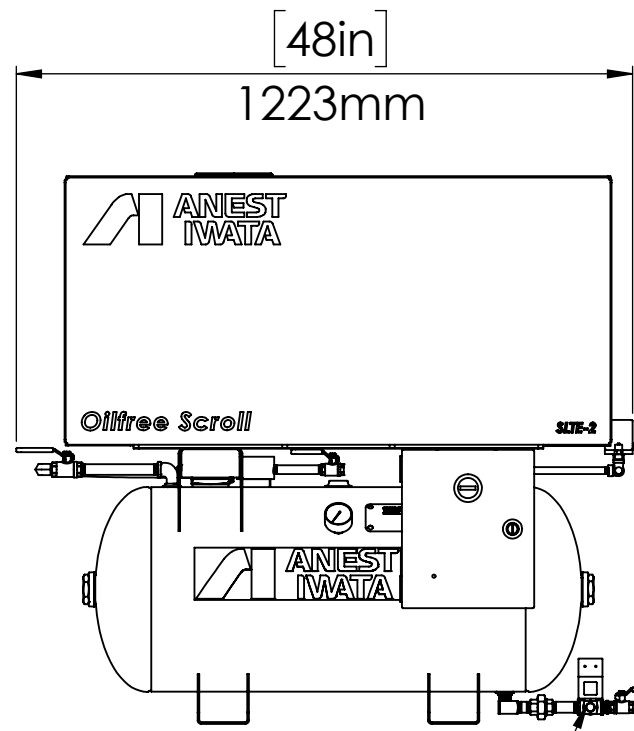

1/2" NPT AUTO DRAIN CONNECTION

1/4" NPT DRAIN VALVE

NOTES:
1) SPECIFICATIONS MAY BE CHANGED WITHOUT NOTICE

- NOTES:
- 1) COMPRESSOR UNIT MUST BE INSTALLED IN A ROOM ON A FLAT FLOOR
 - 2) COMPRESSOR IS AN AIR COOLED UNIT - ROOM TEMPERATURE MUST NOT EXCEED 104° F EXHAUST DUCTS OR VENTILATING FAN MUST BE INSTALLED IF ROOM TEMPERATURE EXCEEDS 104° F
 - 3) PROVIDE ADEQUATE SPACE DURING INSTALLATION FOR NECESSARY MAINTENANCE AND REPAIRS ALLOW A MINIMUM OF 20" ON EACH SIDE AND 24" FROM TOP OF UNIT FROM WALLS
 - 4) CARE MUST BE TAKEN TO INSURE COMPRESSOR UNIT DOES NOT INTAKE HOT AIR OR DUST
 - 5) REFER TO INSTRUCTION MANUAL FOR ELECTRIC WIRING DIAGRAM
 - 6) SPEC IS SUBJECT TO CHANGE WITHOUT NOTICE

PROPRIETARY AND CONFIDENTIAL
THE INFORMATION CONTAINED IN THIS DRAWING IS THE SOLE PROPERTY OF ANEST IWATA. ANY REPRODUCTION IN PART OR AS A WHOLE WITHOUT THE WRITTEN PERMISSION OF ANEST IWATA IS PROHIBITED.

UNLESS OTHERWISE SPECIFIED: DIMENSIONS ARE IN INCHES AND MILLIMETERS	DRAWN	NAME	DATE	ANEST IWATA Air Engineering Inc. 
	CHECKED	AMM	4/9/20	
	ENG APPR.	AGH	4/20/20	
	MFG APPR.			
INTERPRET GEOMETRIC TOLERANCING PER:	MATERIAL			TITLE: SLTE-2(H)-FM-30 OIL-FREE SCROLL UNIT TANK MOUNT COMPRESSOR FILTER MEMBRANE DRYER
	ASS'Y			
	PART NO.			
DO NOT SCALE DRAWING	COMMENTS:			SIZE B DWG. NO. SLTE-2(H)-FM-30-R2 REV 2
				SCALE: 1:15 WEIGHT: SHEET 1 OF 1