

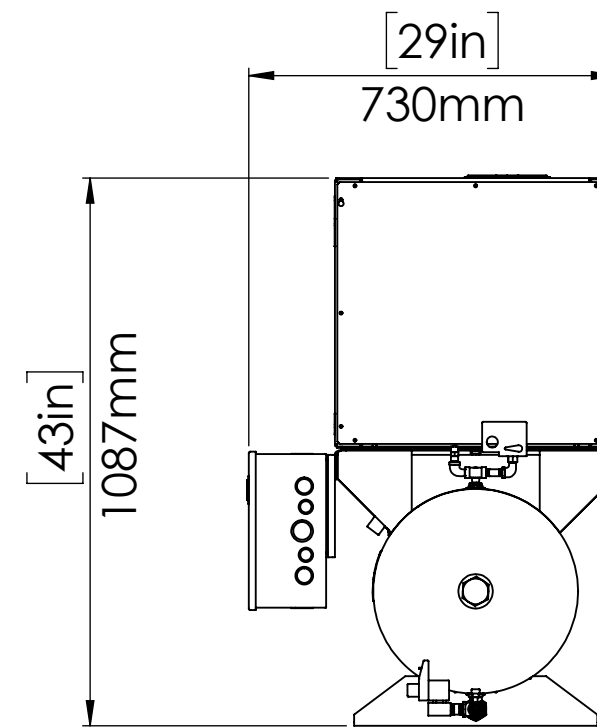

	SLTE-2-30	SLTE-2H-30
HORSEPOWER	2	2
OPERATING PRESSURE (PSI)	85-115	115-145
AIR DELIVERY (CFM)	5.3	4.5
CONTROL SYSTEM	MULTIPLE UNIT CONTROL - AUTO/START STOP	
NOISE LEVEL (dB A)	50	
AIR OUTLET (BALL VALVE)	1/2" NPT	
OPERATING VOLTAGE	1 PHASE, 115/208-230V, 60Hz 3 PHASE, 208-230/460V, 60Hz	
DIMENSIONS (L x W x H)	48" x 29" x 43"	
APPROX. WT. (LBS.)	370	

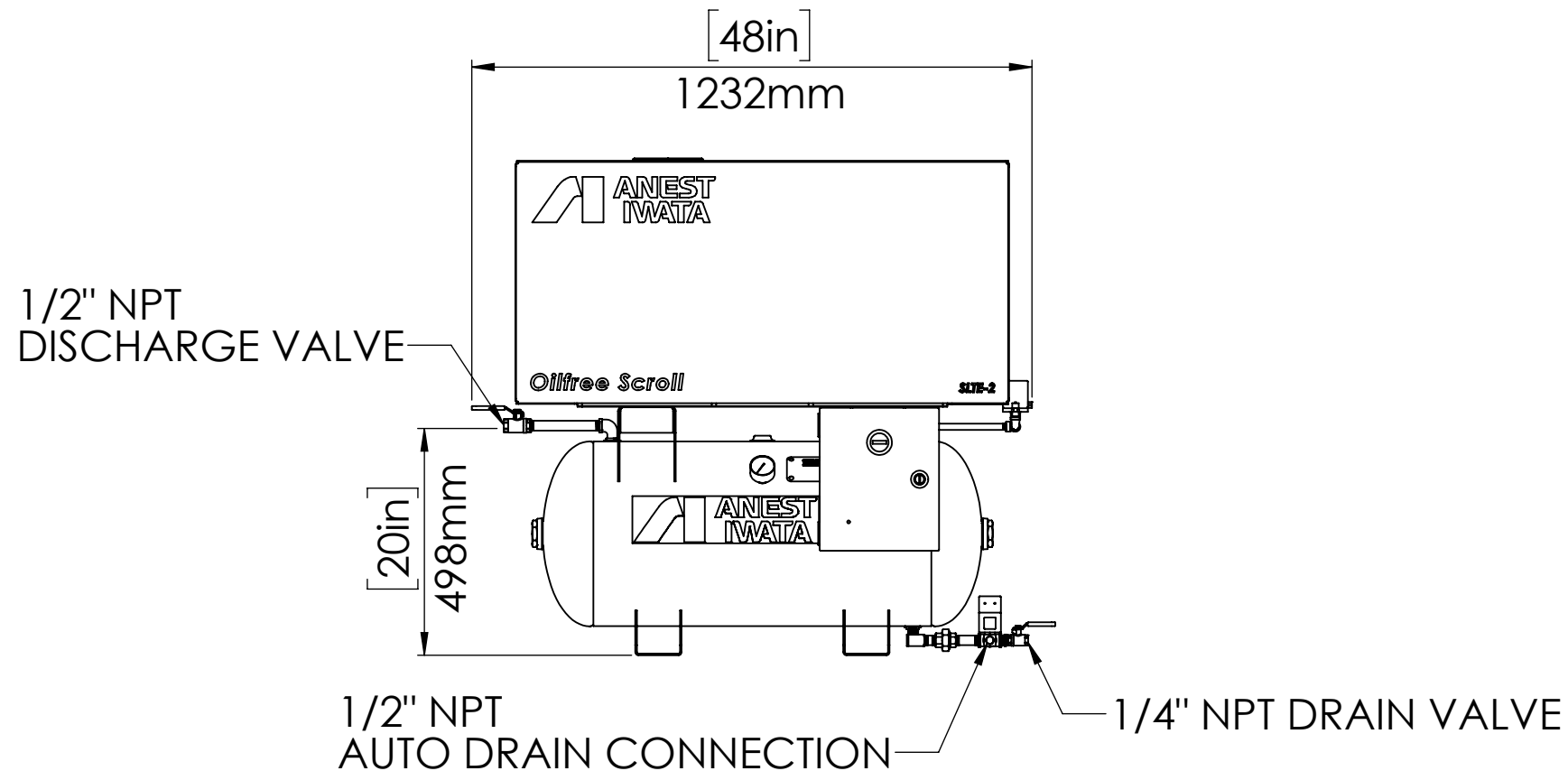

- NOTES:
- 1) COMPRESSOR UNIT MUST BE INSTALLED IN A ROOM ON A FLAT FLOOR
  - 2) COMPRESSOR IS AN AIR COOLED UNIT - ROOM TEMPERATURE MUST NOT EXCEED 104° F  
EXHAUST DUCTS OR VENTILATING FAN MUST BE INSTALLED IF ROOM TEMPERATURE EXCEEDS 104° F
  - 3) PROVIDE ADEQUATE SPACE DURING INSTALLATION FOR NECESSARY MAINTENANCE AND REPAIRS  
ALLOW A MINIMUM OF 20" ON EACH SIDE AND 24" FROM TOP OF UNIT FROM WALLS
  - 4) CARE MUST BE TAKEN TO INSURE COMPRESSOR UNIT DOES NOT INTAKE HOT AIR OR DUST
  - 5) REFER TO INSTRUCTION MANUAL FOR ELECTRIC WIRING DIAGRAM
  - 6) SPEC IS SUBJECT TO CHANGE WITHOUT NOTICE

**PROPRIETARY AND CONFIDENTIAL**  
THE INFORMATION CONTAINED IN THIS DRAWING IS THE SOLE PROPERTY OF ANEST IWATA. ANY REPRODUCTION IN PART OR AS A WHOLE WITHOUT THE WRITTEN PERMISSION OF ANEST IWATA IS PROHIBITED.

UNLESS OTHERWISE SPECIFIED:	NAME	DATE	ANEST IWATA Air Engineering Inc. 
DIMENSIONS ARE IN INCHES	DRAWN	AMM 4/16/20	
	CHECKED	AGH 4/17/20	
	ENG APPR.		
	MFG APPR.		
INTERPRET GEOMETRIC TOLERANCING PER:	Q.A.		TITLE: <b>SLTE-2(H)-30</b> OIL-FREE SCROLL UNIT TANK MOUNT COMPRESSOR
MATERIAL	COMMENTS:		
ASS'Y			
PART NO.			SIZE <b>B</b> DWG. NO. <b>SLTE-2(H)-30-R2</b> REV <b>2</b>
DO NOT SCALE DRAWING			SCALE: 1:15 WEIGHT: SHEET 1 OF 1