

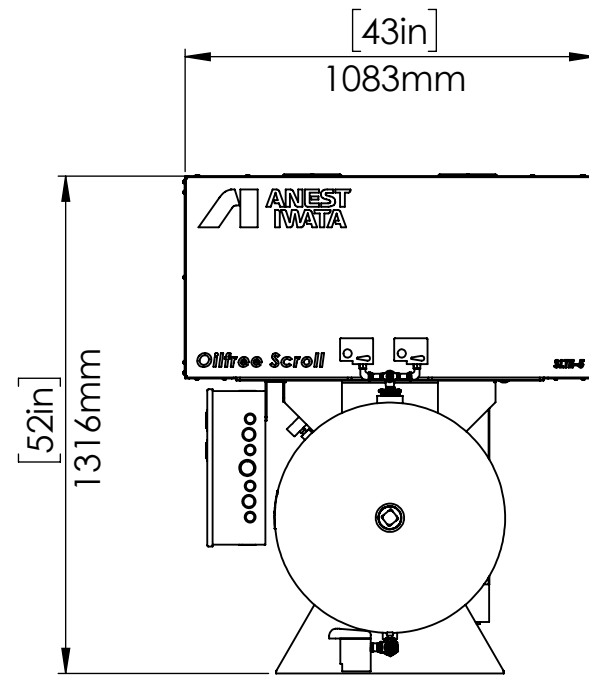

	SLTE-10D-FM-120	SLTE-10DH-FM-120
HORSEPOWER	10	
OPERATING PRESSURE (PSI)	85-115 (LEAD PUMP) 75-105 (SECOND PUMP)	115-145 (LEAD PUMP) 105-135 (SECOND PUMP)
AIR DELIVERY (CFM)	26.8	21.3
CONTROL SYSTEM	MULTIPLE UNIT CONTROL - AUTO START/STOP	
NOISE LEVEL (dB A)	62	
AIR OUTLET (BALL VALVE)	3/4" NPT	
OPERATING VOLTAGE	3 PHASE, 208-230V/460V, 60Hz	
DIMENSIONS (LxWxH)	75" x 43" x 52"	
APPROX. WT. (LBS.)	815	

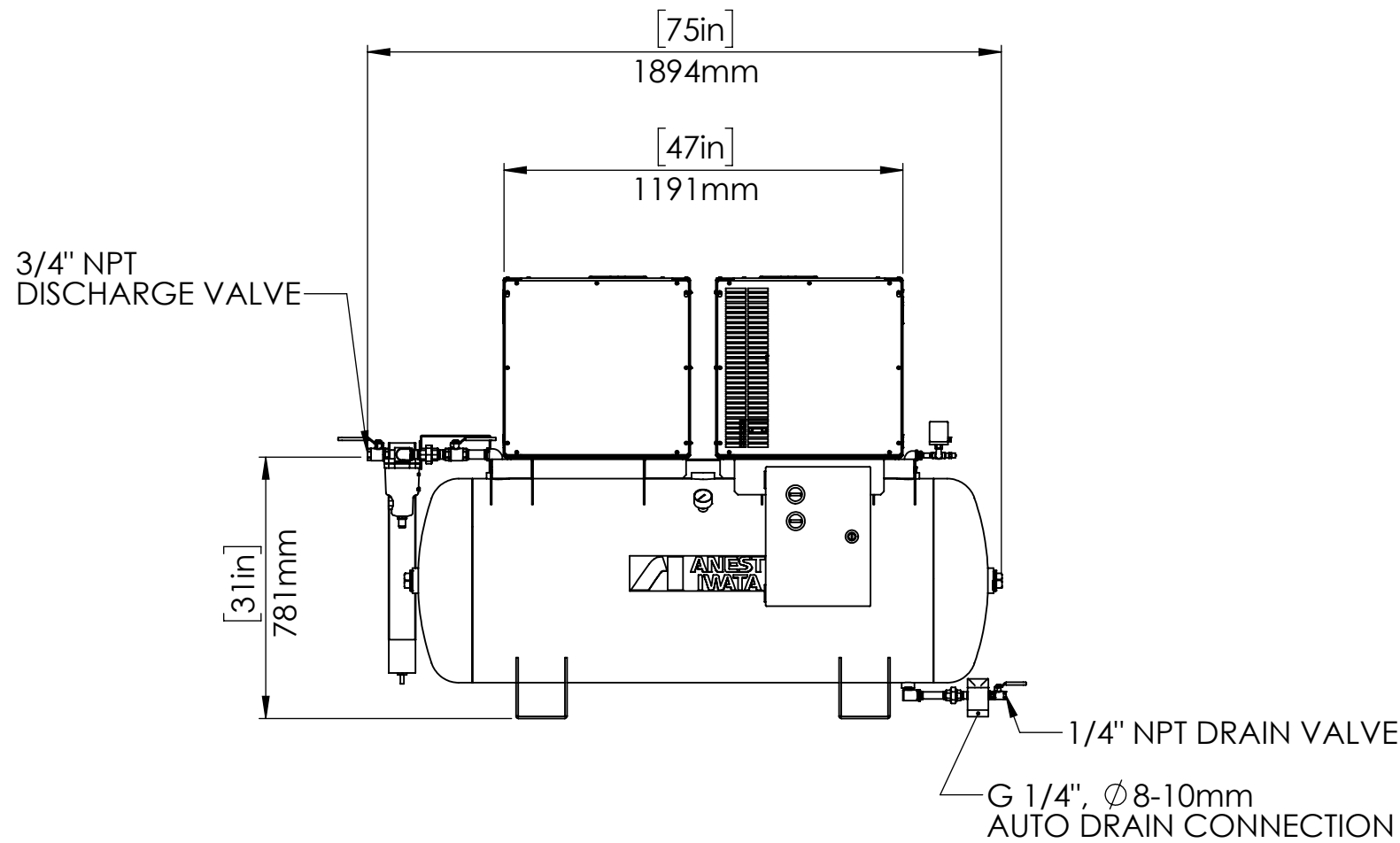

- NOTES:**
- 1) COMPRESSOR UNIT MUST BE INSTALLED IN A ROOM ON A FLAT FLOOR
 - 2) COMPRESSOR IS AN AIR COOLED UNIT - ROOM TEMPERATURE MUST NOT EXCEED 104° F
EXHAUST DUCTS OR VENTILATING FAN MUST BE INSTALLED IF ROOM TEMPERATURE EXCEEDS 104° F
 - 3) PROVIDE ADEQUATE SPACE DURING INSTALLATION FOR NECESSARY MAINTENANCE AND REPAIRS
ALLOW A MINIMUM OF 20" ON EACH SIDE AND 24" FROM TOP OF UNIT FROM WALLS
 - 4) CARE MUST BE TAKEN TO INSURE COMPRESSOR UNIT DOES NOT INTAKE HOT AIR OR DUST
 - 5) REFER TO INSTRUCTION MANUAL FOR ELECTRIC WIRING DIAGRAM
 - 6) SPEC IS SUBJECT TO CHANGE WITHOUT NOTICE

PROPRIETARY AND CONFIDENTIAL
THE INFORMATION CONTAINED IN THIS DRAWING IS THE SOLE PROPERTY OF ANEST IWATA. ANY REPRODUCTION IN PART OR AS A WHOLE WITHOUT THE WRITTEN PERMISSION OF ANEST IWATA IS PROHIBITED.

UNLESS OTHERWISE SPECIFIED:	NAME	DATE	ANEST IWATA Air Engineering Inc. 	
DIMENSIONS ARE SHOWN IN INCHES AND MILLIMETERS	DRAWN	AMM		4/15/20
	CHECKED	AGH		4/23/20
	ENG APPR.			
	MFG APPR.			
INTERPRET GEOMETRIC TOLERANCING PER:	Q.A.			
MATERIAL	COMMENTS:			
ASS'Y				
PART NO.				
DO NOT SCALE DRAWING				
TITLE:			 SLTE-10D(H)-FM-120 OIL-FREE SCROLL UNIT TANK MOUNT COMPRESSOR FILTER MEMBRANE DRYER	
SIZE	DWG. NO.	REV		
B	SLTE-10D(H)-FM-120-R1	1		
SCALE: 1:20		WEIGHT:	SHEET 1 OF 1	