

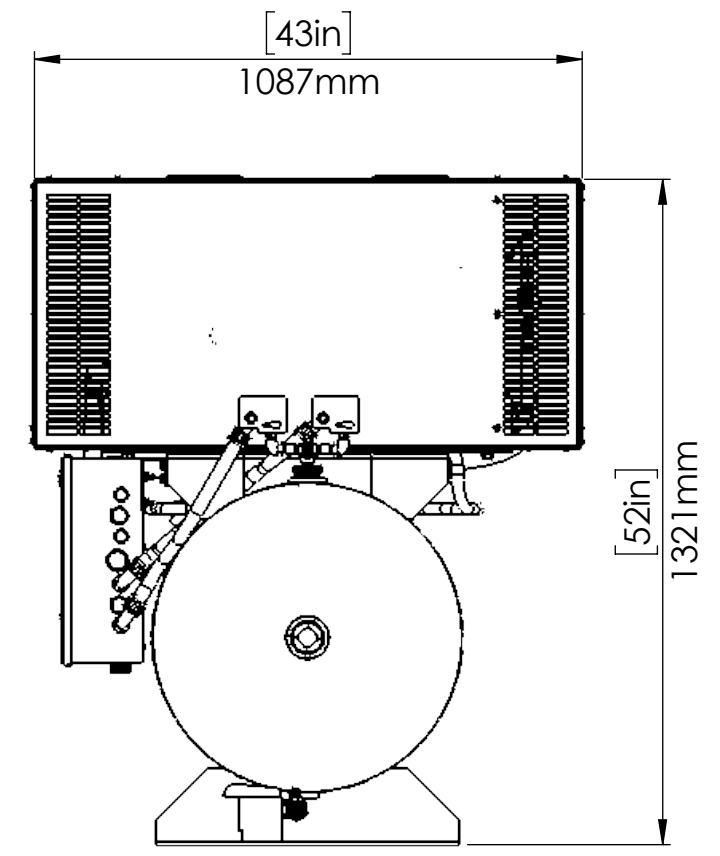

	SLTE-10D-120	SLTE-10DH-120
HORSEPOWER	10	
OPERATING PRESSURE (PSI)	85-115 (LEAD PUMP) 75-105 (SECOND PUMP)	115-145 (LEAD PUMP) 105-135 (SECOND PUMP)
AIR DELIVERY (CFM)	29.6	23.4
CONTROL SYSTEM	MULTIPLE UNIT CONTROL - AUTO START/STOP	
NOISE LEVEL (dB A)	62	
AIR OUTLET (BALL VALVE)	3/4" NPT	
OPERATING VOLTAGE	3 PHASE, 208-230V/460V, 60Hz	
DIMENSIONS (LxWxH)	68" x 43" x 52"	
APPROX. WT. (LBS.)	800	

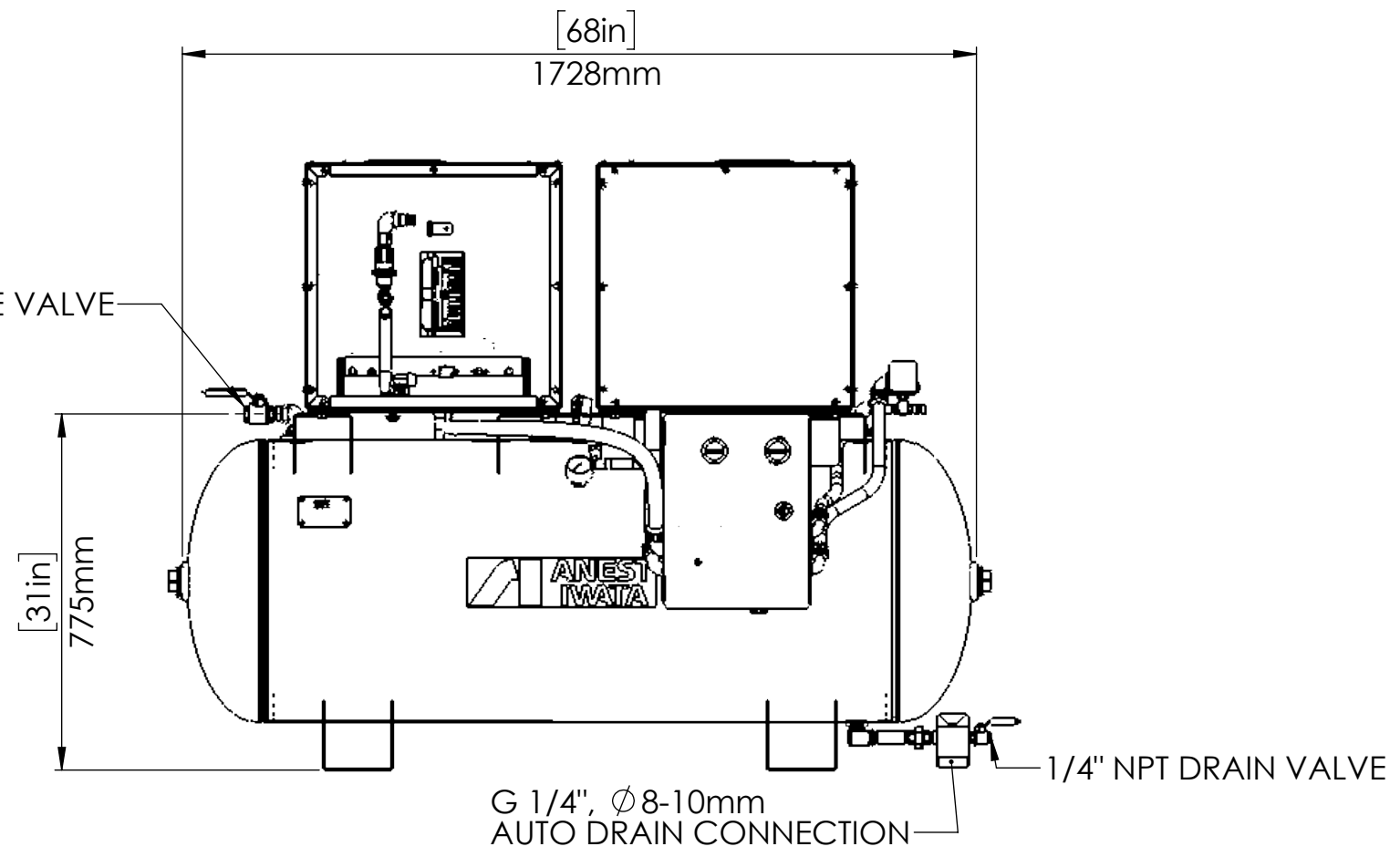

- NOTES:**
- 1) COMPRESSOR UNIT MUST BE INSTALLED IN A ROOM ON A FLAT FLOOR
 - 2) COMPRESSOR IS AN AIR COOLED UNIT - ROOM TEMPERATURE MUST NOT EXCEED 104° F
EXHAUST DUCTS OR VENTILATING FAN MUST BE INSTALLED IF ROOM TEMPERATURE EXCEEDS 104° F
 - 3) PROVIDE ADEQUATE SPACE DURING INSTALLATION FOR NECESSARY MAINTENANCE AND REPAIRS
ALLOW A MINIMUM OF 20" ON EACH SIDE AND 24" FROM TOP OF UNIT FROM WALLS
 - 4) CARE MUST BE TAKEN TO INSURE COMPRESSOR UNIT DOES NOT INTAKE HOT AIR OR DUST
 - 5) REFER TO INSTRUCTION MANUAL FOR ELECTRIC WIRING DIAGRAM
 - 6) SPEC IS SUBJECT TO CHANGE WITHOUT NOTICE

PROPRIETARY AND CONFIDENTIAL
THE INFORMATION CONTAINED IN THIS DRAWING IS THE SOLE PROPERTY OF **ANEST IWATA**. ANY REPRODUCTION IN PART OR AS A WHOLE WITHOUT THE WRITTEN PERMISSION OF **ANEST IWATA** IS PROHIBITED.

UNLESS OTHERWISE SPECIFIED:		NAME	DATE
DIMENSIONS ARE SHOWN IN INCHES AND MILLIMETERS	DRAWN	AGH	4/13/20
	CHECKED	AMM	4/14/20
	ENG APPR.		
	MFG APPR.		
INTERPRET GEOMETRIC TOLERANCING PER:	Q.A.		
MATERIAL	COMMENTS:		
PART NO.	ASS'Y		
DO NOT SCALE DRAWING			

ANEST IWATA Air Engineering Inc.		
TITLE: SLTE-10D(H)-120 OIL-FREE SCROLL UNIT TANK MOUNT COMPRESSOR		
SIZE B	DWG. NO. SLTE-10D(H)-120-R1	REV 1
SCALE: 1:15 WEIGHT:		SHEET 1 OF 1