

	SLT-7.5-80	SLT-7.5H-80
HORSEPOWER	7.5	
OPERATING PRESSURE (PSI)	85-115	115-145
AIR DELIVERY (CFM)	22.6	16.2
CONTROL SYSTEM	MULTIPLE UNIT CONTROL - AUTO START/STOP	
NOISE LEVEL (dB A)	74	
AIR OUTLET (BALL VALVE)	3/4" NPT	
OPERATING VOLTAGE	3 PHASE, 208-230V/460V, 60Hz	
DIMENSIONS (LxWxH)	64" x 29" x 48"	
APPROX. WT. (LBS.)	550	

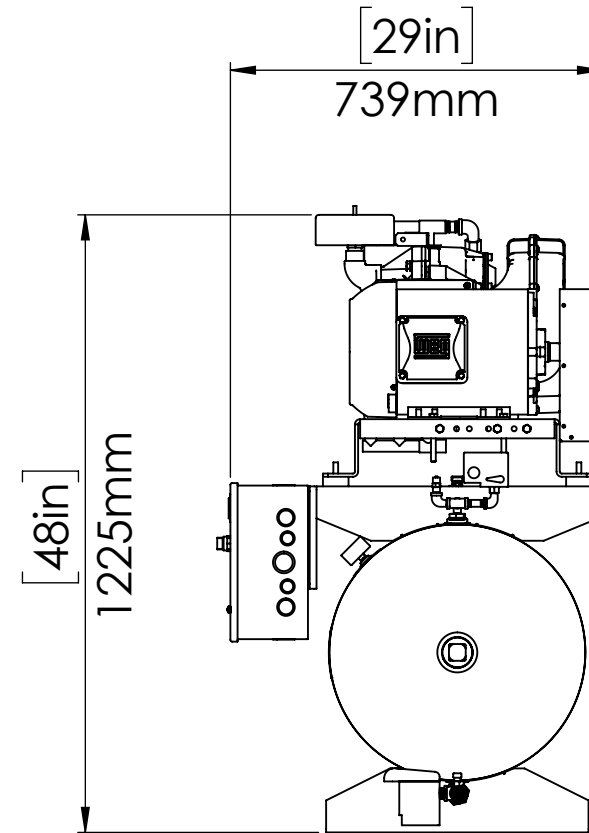
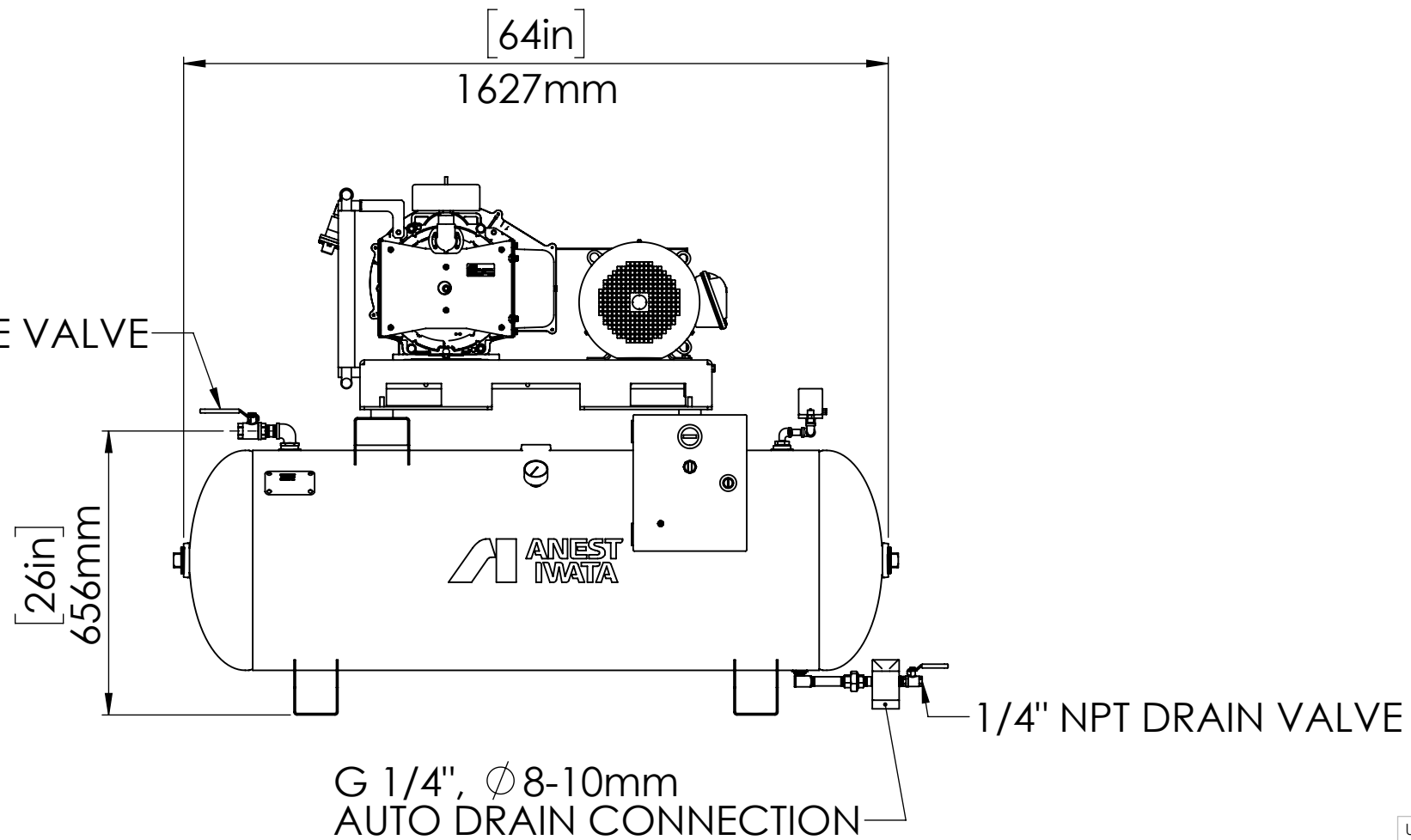

NOTES:

- 1) COMPRESSOR UNIT MUST BE INSTALLED IN A ROOM ON A FLAT FLOOR
- 2) COMPRESSOR IS AN AIR COOLED UNIT - ROOM TEMPERATURE MUST NOT EXCEED 104° F
EXHAUST DUCTS OR VENTILATING FAN MUST BE INSTALLED IF ROOM TEMPERATURE EXCEEDS 104° F
- 3) PROVIDE ADEQUATE SPACE DURING INSTALLATION FOR NECESSARY MAINTENANCE AND REPAIRS
ALLOW A MINIMUM OF 20" ON EACH SIDE AND 24" FROM TOP OF UNIT FROM WALLS
- 4) CARE MUST BE TAKEN TO INSURE COMPRESSOR UNIT DOES NOT INTAKE HOT AIR OR DUST
- 5) REFER TO INSTRUCTION MANUAL FOR ELECTRIC WIRING DIAGRAM
- 6) SPEC IS SUBJECT TO CHANGE WITHOUT NOTICE

PROPRIETARY AND CONFIDENTIAL
THE INFORMATION CONTAINED IN THIS DRAWING IS THE SOLE PROPERTY OF **ANEST IWATA**. ANY REPRODUCTION IN PART OR AS A WHOLE WITHOUT THE WRITTEN PERMISSION OF **ANEST IWATA** IS PROHIBITED.

UNLESS OTHERWISE SPECIFIED:		NAME	DATE	ANEST IWATA Air Engineering Inc.
DIMENSIONS ARE SHOWN IN INCHES AND MILLIMETERS		DRAWN	Y.T 6/24/21	
		CHECKED		
		ENG APPR.		
		MFG APPR.		TITLE: SLT-7.5(H)-80 OIL FREE SCROLL UNIT TANK MOUNTED COMPRESSOR
		Q.A.		
		COMMENTS:		SIZE DWG. NO. REV B SLT-7.5(H)-80
MATERIAL ASS'Y				
PART NO.				SCALE: 1:15 WEIGHT: SHEET 1 OF 1
DO NOT SCALE DRAWING				