

	SLT-10D-FM-120	SLT-10DH-FM-120
HORSEPOWER	10	
OPERATING PRESSURE (PSI)	85-115 (LEAD PUMP) 75-105 (SECOND PUMP)	115-145 (LEAD PUMP) 105-135 (SECOND PUMP)
AIR DELIVERY (CFM)	26.8	21.3
CONTROL SYSTEM	MULTIPLE UNIT CONTROL - AUTO START/STOP	
NOISE LEVEL (dB A)	72	
AIR OUTLET (BALL VALVE)	3/4" NPT	
OPERATING VOLTAGE	3 PHASE, 208-230V/460V, 60Hz	
DIMENSIONS (LxWxH)	75" x 37" x 47"	
APPROX. WT. (LBS.)	720	

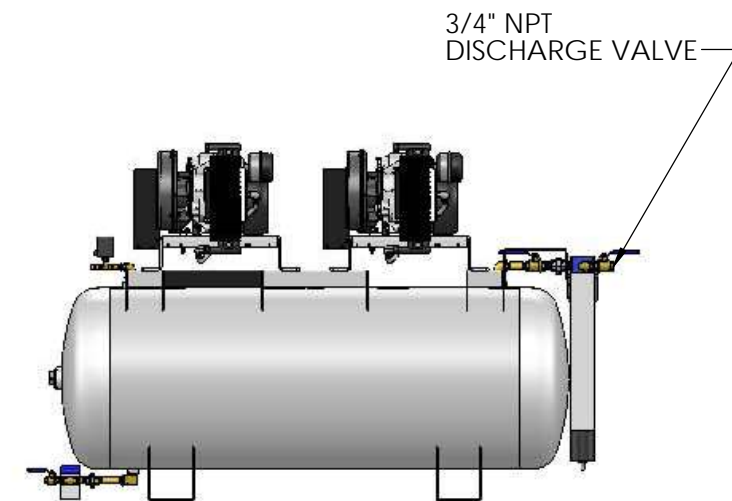
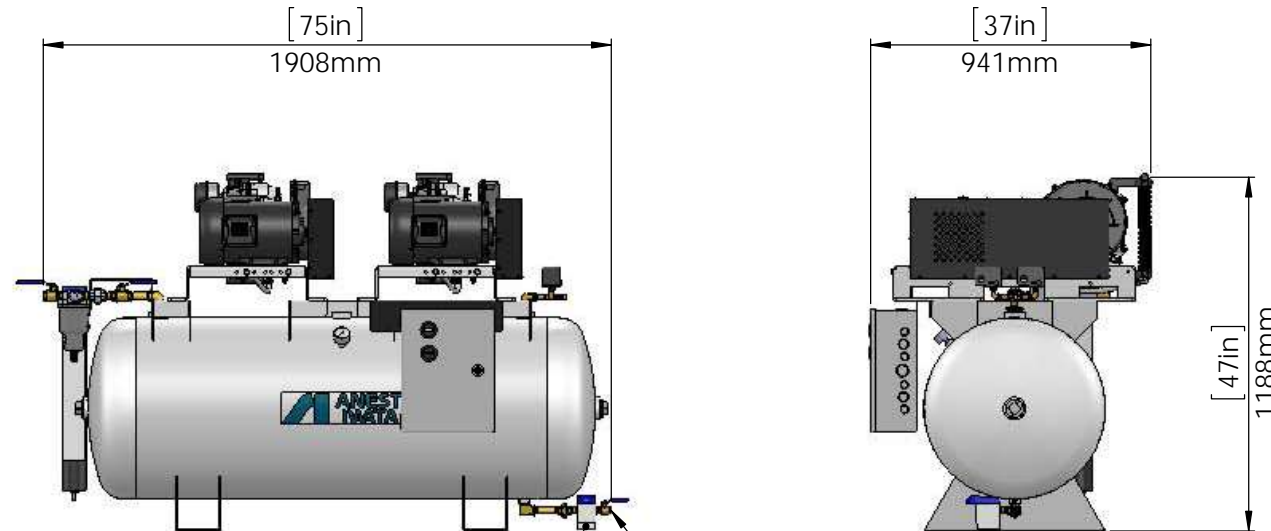
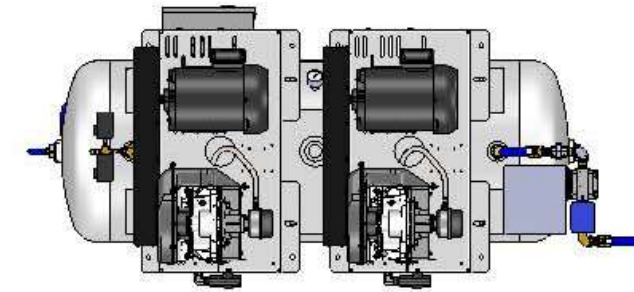

1/4" NPT DRAIN VALVE
G 1/4", Ø8-10mm
AUTO DRAIN CONNECTION

PROPRIETARY AND CONFIDENTIAL
THE INFORMATION CONTAINED IN THIS DRAWING IS THE SOLE PROPERTY OF ANEST IWATA Air Engineering Inc. ANY REPRODUCTION IN PART OR AS A WHOLE WITHOUT THE WRITTEN PERMISSION OF ANEST IWATA Air Engineering Inc. IS PROHIBITED.

		UNLESS OTHERWISE SPECIFIED:		NAME	DATE	ANEST IWATA Air Engineering Inc.
				GJC	1/7/16	
			INTERPRET GEOMETRIC TOLERANCING PER:			SIZE DWG. NO. REV B SLT-10D(H)-FM-120
NEXT ASSY	USED ON					
APPLICATION			DO NOT SCALE DRAWING			SCALE: 1:20 WEIGHT: SHEET 1 OF 1