

	SLE-1 (H)	SLE-2 (H)	SLE-3 (H)	SLE-5 (H)
HORSE POWER (HP)	1	2	3	5
OPERATING PRESSURE (PSI)	85 -115 (115 to 145)			
AIR DELIVERY (CFM)	2.6 (1.8)	5.3 (4.5)	7.8 (6.4)	14.8 (11.7)
PRESSURE DEW POINT (°F)	LESS THAN 59			
CONTROL SYSTEM	MULTIPLE UNIT CONTROL - AUTO START/STOP			
NOISE LEVEL (dB A)	46	46	50	50
AIR OUTLET (BALL VALVE)	1/2" NPT			
OPERATING VOLTAGE	1 PHASE, 115V/208-230V*1, 60HZ ~ 3 PHASE, 208-230V/460V*1, 60HZ			
AIR RECEIVER VOLUME (GAL)	7			
DIMENSIONS (LxWxH)	22" x 24" x 42"			
APPROX. WT. (LBS)	240	260	270	280

*1 DIFFERS DEPENDING ON THE HORSE POWER

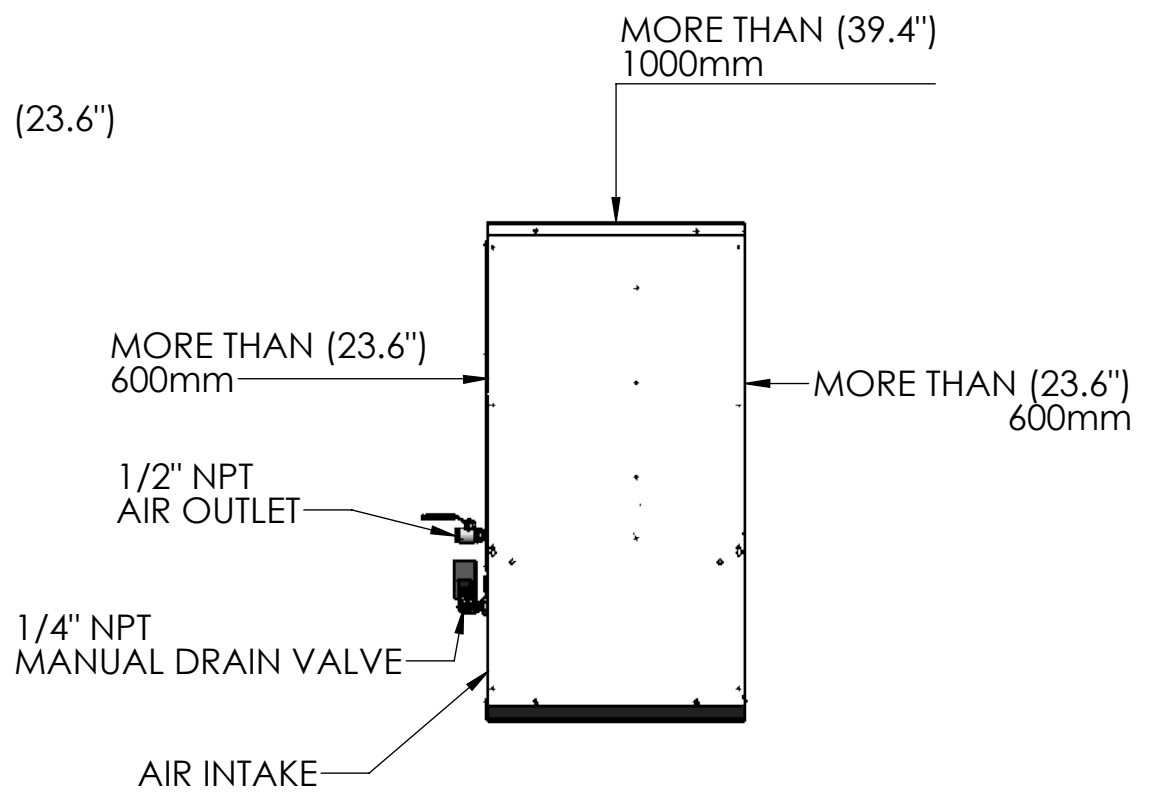
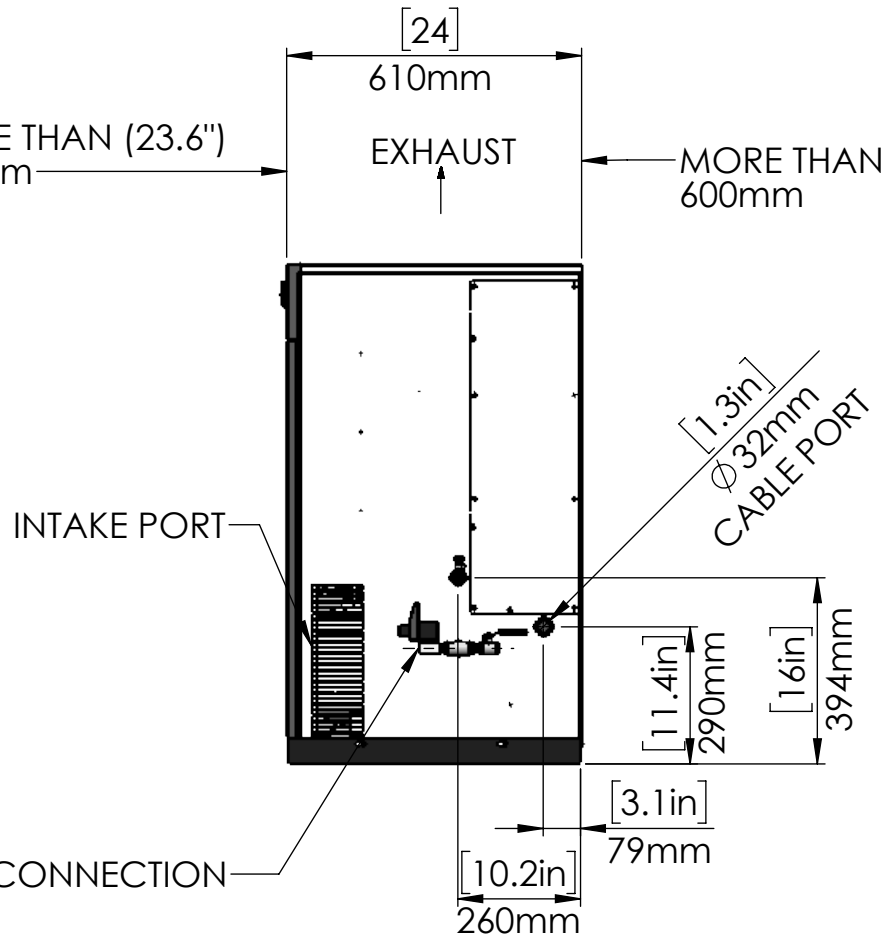
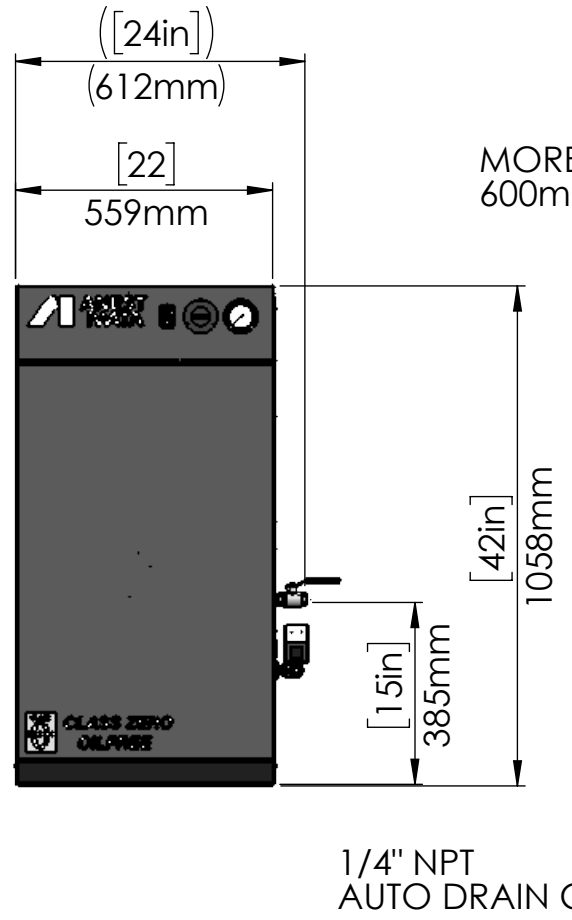

- NOTES:
- 1) COMPRESSOR UNIT MUST BE INSTALLED IN A ROOM ON A FLAT FLOOR
 - 2) COMPRESSOR IS AN AIR COOLED UNIT - ROOM TEMPERATURE MUST NOT EXCEED 104°F
EXHAUST DUCTS OR VENTILATING FAN MUST BE INSTALLED IF ROOM TEMPERATURE EXCEEDS 104° F
 - 3) PROVIDE ADEQUATE SPACE DURING INSTALLATION FOR NECESSARY MAINTENANCE AND REPAIRS
ALLOW A MINIMUM OF 23.6" ON EACH SIDE AND 39.4" FROM TOP OF UNIT FROM WALLS
 - 4) CARE MUST BE TAKEN TO INSURE COMPRESSOR UNIT DOES NOT INTAKE HOT AIR OR DUST
 - 5) REFER TO INSTRUCTION MANUAL FOR ELECTRIC WIRING DIAGRAM
 - 6) SPEC IS SUBJECT TO CHANGE WITHOUT NOTICE

PROPRIETARY AND CONFIDENTIAL
THE INFORMATION CONTAINED IN THIS DRAWING IS THE SOLE PROPERTY OF ANEST IWATA. ANY REPRODUCTION IN PART OR AS A WHOLE WITHOUT THE WRITTEN PERMISSION OF ANEST IWATA IS PROHIBITED.

UNLESS OTHERWISE SPECIFIED:		NAME	DATE	
DIMENSIONS ARE IN INCHES	DRAWN	AMM	4/17/20	
	CHECKED	SDR	4/30/20	
	ENG APPR.			
	MFG APPR.			
INTERPRET GEOMETRIC TOLERANCING PER:		Q.A.		TITLE: SLE-1, 2, 3, & 5 OIL-FREE SCROLL COMPRESSOR
MATERIAL	ASSY	COMMENTS:		
PART NO.				SIZE DWG. NO. REV B SLE-1_2_3_5-R1 1
DO NOT SCALE DRAWING				SCALE: 1:16 WEIGHT: SHEET 1 OF 1