

8 7 6 5 4 3 2 1

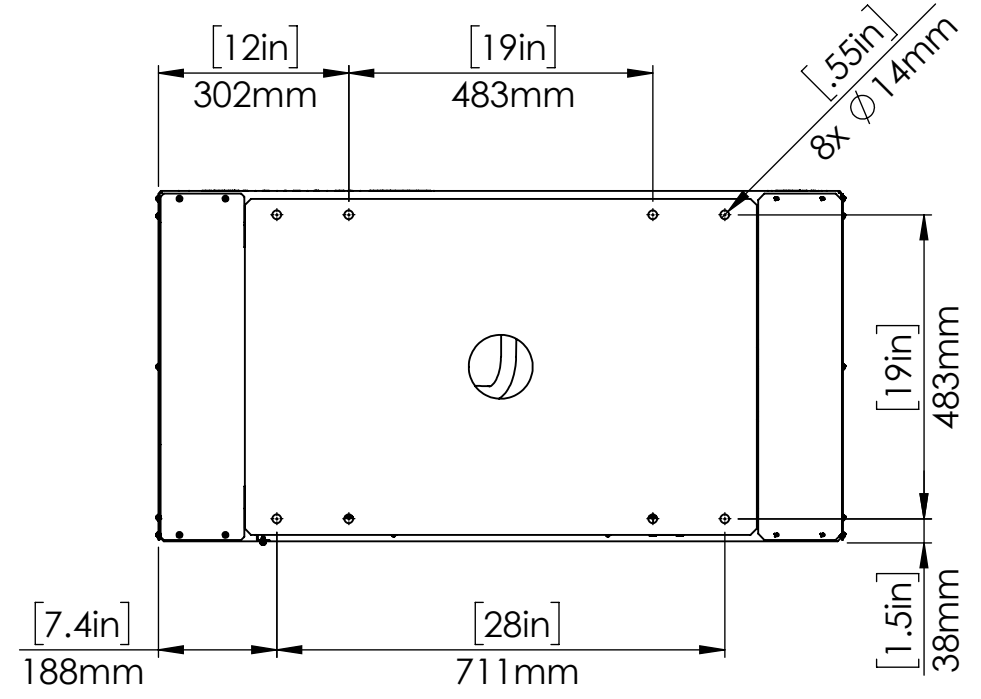
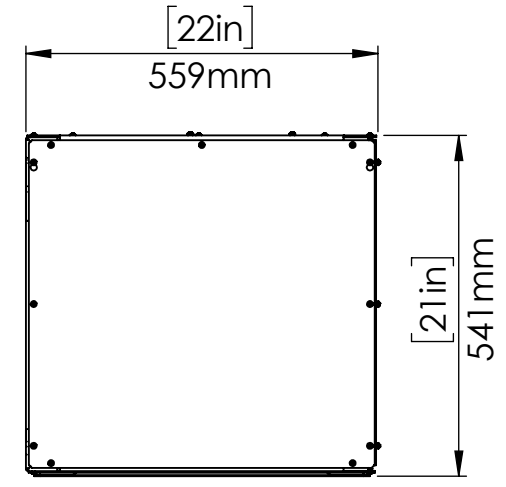
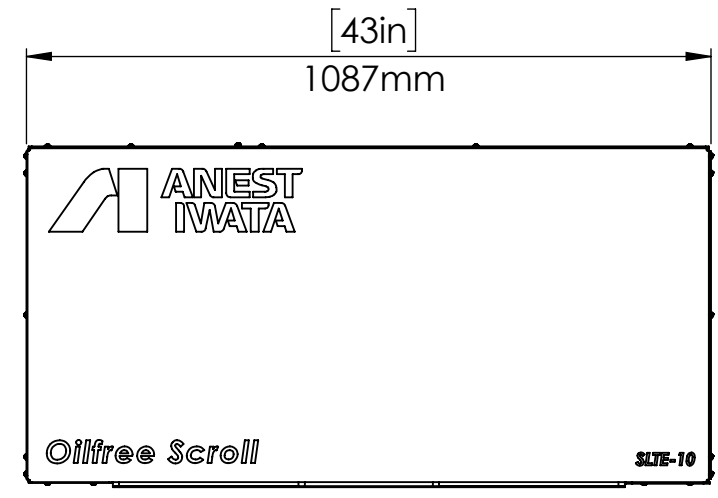

	SLBE-2	SLBE-2H	SLBE-3	SLBE-3H	SLBE-5	SLBE-5H	SLBE-7.5	SLBE-7.5H	SLBE-10	SLBE-10H
HORSEPOWER	2		3		5		7.5		10	
MAX OPERATING ORESSURE (PSI)	115	145	115	145	115	145	115	145	115	145
AIR DELIVERY (CFM)	5.3	4.5	7.8	6.4	14.8	11.7	22.6	TBD	29.7	TBD
AIR OUTLET	3/8" NPT OUTLET									
OPERATING VOLTAGE	3 PHASE, 208-230V/460V, 60 HZ									
DIMINSIONS (INCHES)	43" X 22" X 21"									
APPROX WEIGHT (LBS.)	270		285		310		390		440	

- NOTES:**
- 1) COMPRESSOR UNIT MUST BE INSTALLED IN A ROOM ON A FLAT FLOOR
 - 2) COMPRESSOR IS AN AIR COOLED UNIT - ROOM TEMPERATURE MUST NOT EXCEED 104° F EXHAUST DUCTS OR VENTILATING FAN MUST BE INSTALLED IF ROOM TEMPERATURE EXCEEDS 104° F
 - 3) PROVIDE ADEQUATE SPACE DURING INSTALLATION FOR NECESSARY MAINTENANCE AND REPAIRS ALLOW A MINIMUM OF 20" ON EACH SIDE AND 24" FROM TOP OF UNIT FROM WALLS
 - 4) CARE MUST BE TAKEN TO INSURE COMPRESSOR UNIT DOES NOT INTAKE HOT AIR OR DUST
 - 5) REFER TO INSTRUCTION MANUAL FOR ELECTRIC WIRING DIAGRAM
 - 6) SPEC IS SUBJECT TO CHANGE WITHOUT NOTICE

PROPRIETARY AND CONFIDENTIAL
 THE INFORMATION CONTAINED IN THIS DRAWING IS THE SOLE PROPERTY OF ANEST IWATA. ANY REPRODUCTION IN PART OR AS A WHOLE WITHOUT THE WRITTEN PERMISSION OF ANEST IWATA IS PROHIBITED.

UNLESS OTHERWISE SPECIFIED:		NAME	DATE	 ANEST IWATA Air Engineering Inc.
DIMENSIONS ARE IN INCHES		DRAWN	AMM 5/8/20	
		CHECKED		
		ENG APPR.		
		MFG APPR.		
INTERPRET GEOMETRIC TOLERANCING PER:		Q.A.		TITLE: SLBE-2/3/5/7.5/10 OIL-FREE SCROLL UNIT BASE MOUNT ENCLOSURE COMPRESSOR
MATERIAL		COMMENTS:		
PART NO.				
DO NOT SCALE DRAWING		SIZE	DWG. NO.	REV
		B	SLBE-2_3_5_7.5_10	
		SCALE: 1:12	WEIGHT:	SHEET 1 OF 5

8 7 6 5 4 3 2 1