

SPECIFICATIONS		
MODEL NO.	OFT-7.5-FRD	OFT-10-FRD
HORSEPOWER	7.5HP	10HP
OPERATING PRESSURE (psi)	90-120	
AIR DELIVERY (cfm)	24.0	30.0
NOISE LEVEL (dB)	70	75
AIR OUTLET (BALL VALVE)	1/2" NPT	
OPERATING VOLTAGE	3 Phase, 208-230/460V, 60Hz	
DIMENSIONS (L x W x H)	68 x 47 x 59	
APPROX. WT (lbs)	TBD	

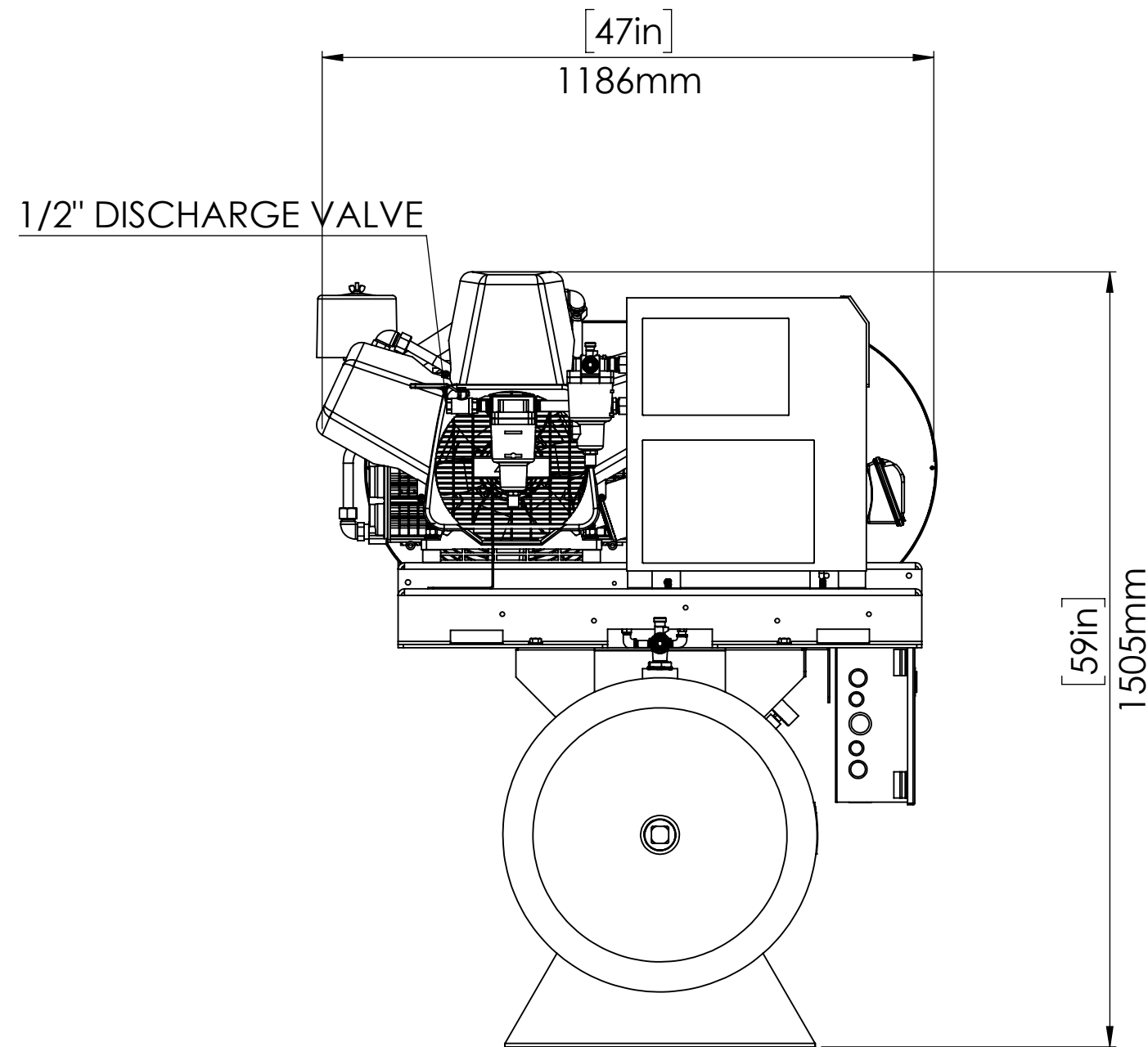
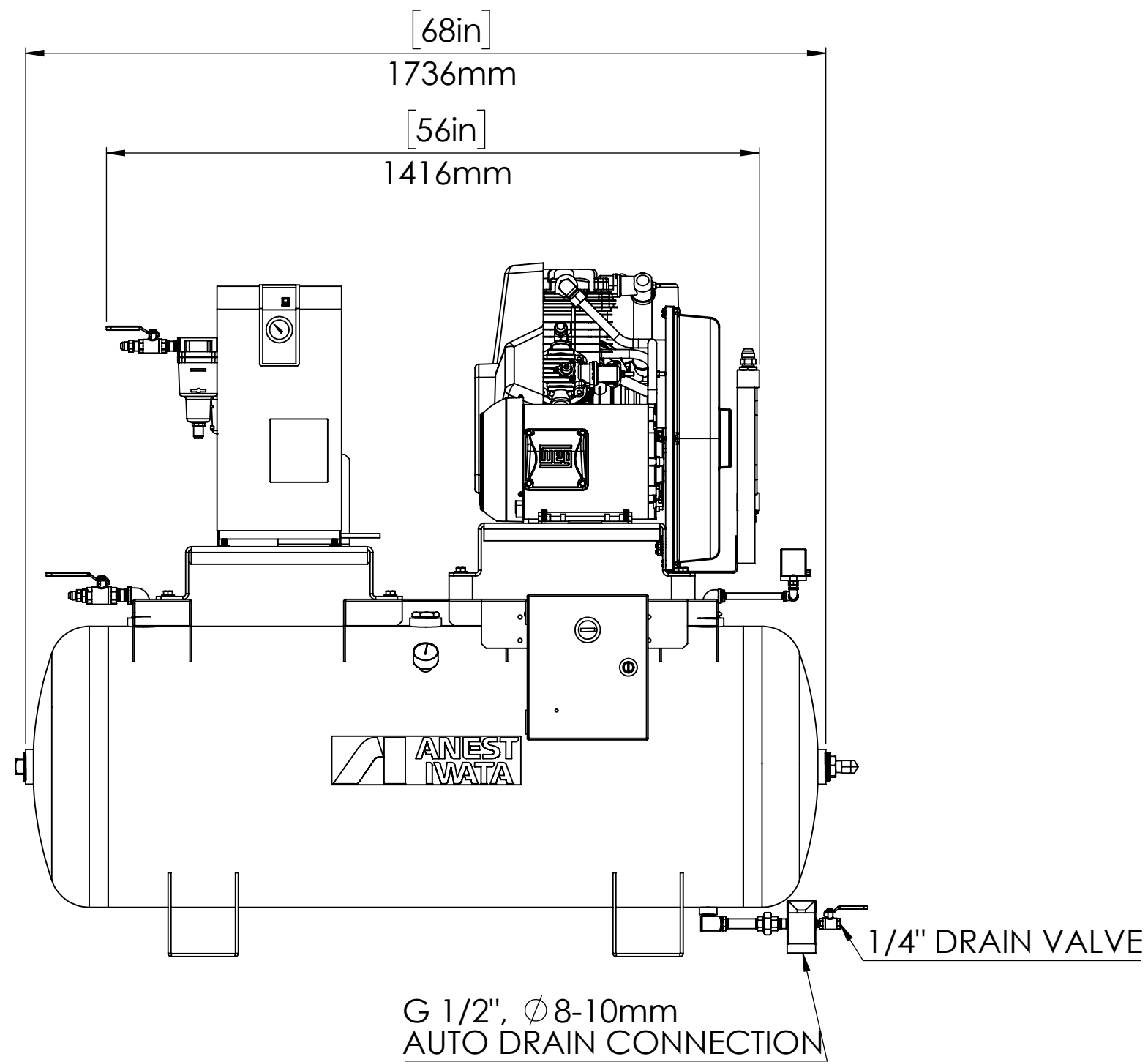

- NOTES:
- 1) COMPRESSOR UNIT MUST BE INSTALLED IN A ROOM ON A FLAT FLOOR.
 - 2) COMPRESSOR IS AN AIR COOLED UNIT - ROOM TEMPERATURE MUST NOT EXCEED 104 °F. EXHAUST DUCTS OR VENTILATING FAN MUST BE INSTALLED IF ROOM TEMPERATURE EXCEEDS 104 °F.
 - 3) PROVIDE ADEQUATE SPACE DURING INSTALLATION FOR NECESSARY MAINTENANCE AND REPAIRS. ALLOW A MINIMUM OF 20" FROM EACH SIDE OF WALL, AND A MINIMUM OF 20" FROM FRONT OF UNIT, AND A MINIMUM OF 24" FROM TOP OF UNIT.
 - 4) CARE MUST BE TAKEN TO INSURE COMPRESSOR UNIT DOES NOT INTAKE HOT AIR OR DUST.
 - 5) REFER TO INSTRUCTION MANUAL FOR ELECTRIC WIRING DIAGRAM.
 - 6) SPEC IS SUBJECT TO CHANGE WITHOUT NOTICE.

PROPRIETARY AND CONFIDENTIAL
 THE INFORMATION CONTAINED IN THIS DRAWING IS THE SOLE PROPERTY OF ANEST IWATA Air Engineering Inc. ANY REPRODUCTION IN PART OR AS A WHOLE WITHOUT THE WRITTEN PERMISSION OF ANEST IWATA Air Engineering Inc. IS PROHIBITED.

UNLESS OTHERWISE SPECIFIED:		NAME	DATE	ANEST IWATA Air Engineering Inc.	
DIMENSIONS ARE IN INCHES		DRAWN	AMM		12/23/19
		CHECKED			
		ENG APPR.			
		MFG APPR.			
		Q.A.			
		COMMENTS:			
NEXT ASSY	USED ON	PART NO.	ASSY		
APPLICATION		DO NOT SCALE DRAWING			
TITLE:		OFT-7.5/10-FRD-120			
7.5/10HP OILLESS RECIPROCATING DRYER DUPLEX		SIZE	DWG. NO.	REV	
C		OFT-7.5_10(H)-FRD-120			
SCALE: 1:12		WEIGHT:	SHEET 1 OF 1		