

SPECIFICATIONS	
MODEL NO.	OFT-15-FRD
HORSEPOWER	15HP
OPERATING PRESSURE (psi)	90-120
AIR DELIVERY (cfm)	41.0
NOISE LEVEL (dB)	74
AIR OUTLET (BALL VALVE)	3/4" NPT
OPERATING VOLTAGE	3 Phase, 208-230/460V, 60Hz
DIMENSIONS (L x W x H)	68 x 47 x 59
APPROX. WT (lbs)	TBD

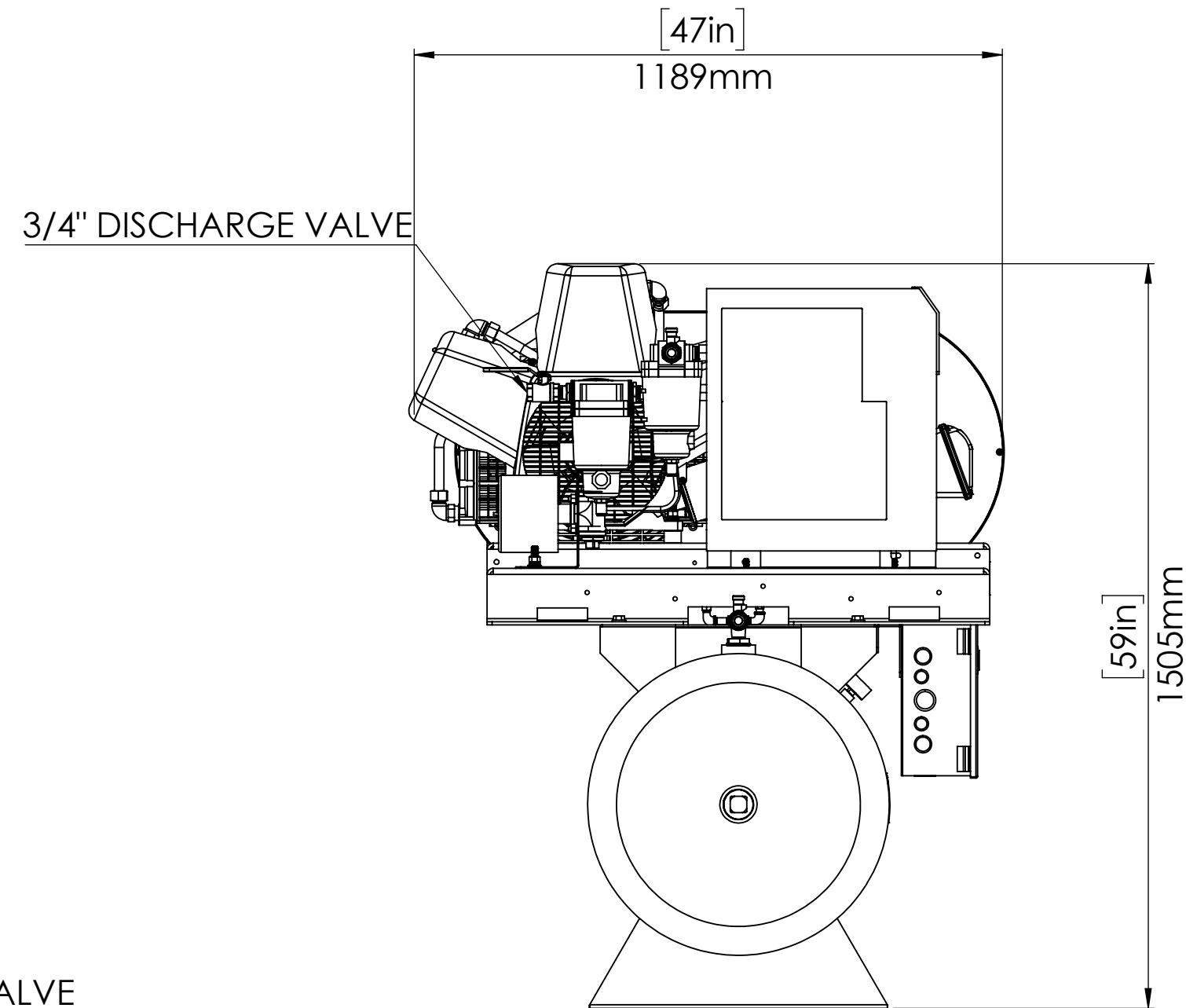
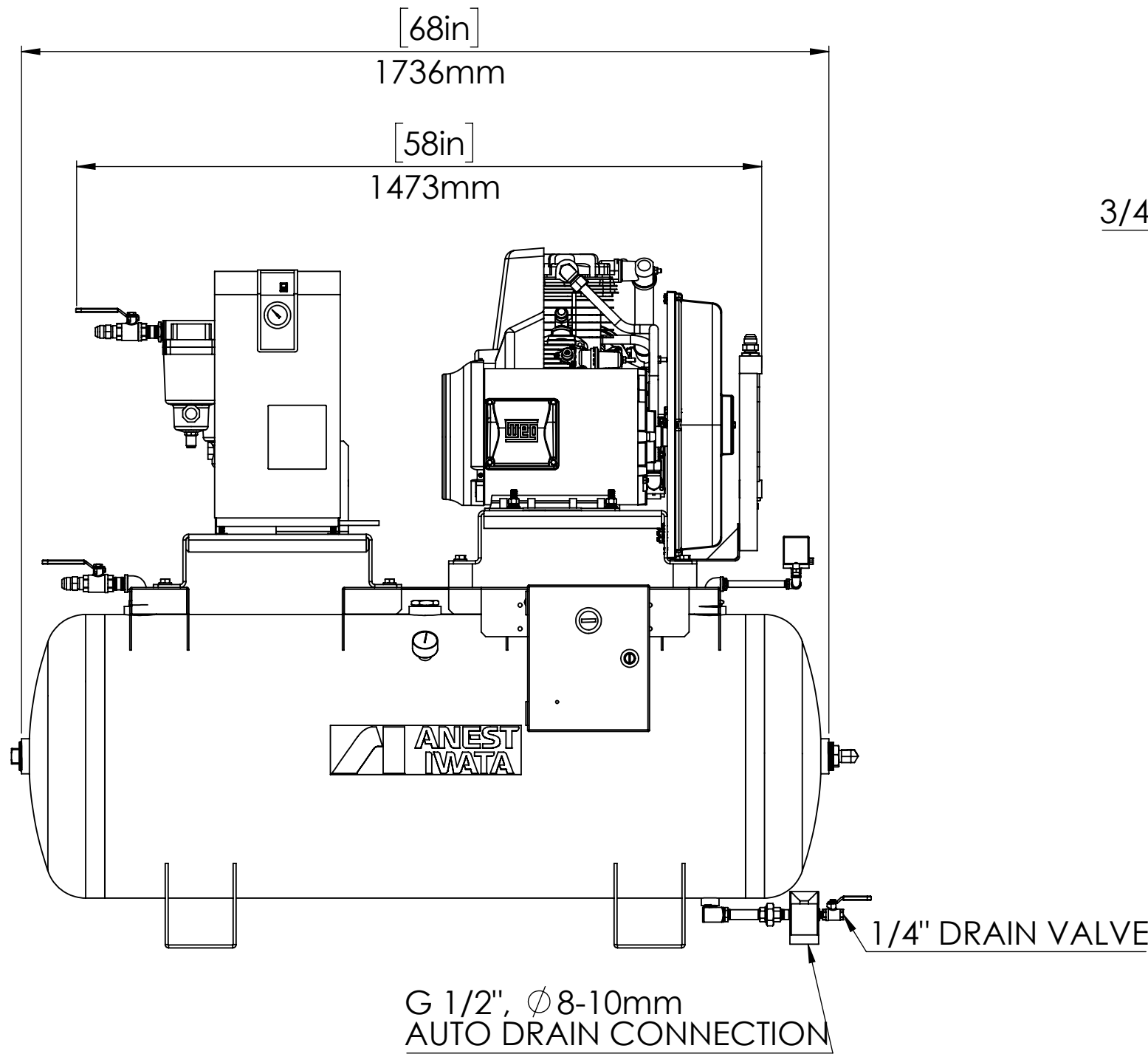

- NOTES:
- 1) COMPRESSOR UNIT MUST BE INSTALLED IN A ROOM ON A FLAT FLOOR.
  - 2) COMPRESSOR IS AN AIR COOLED UNIT - ROOM TEMPERATURE MUST NOT EXCEED 104 °F. EXHAUST DUCTS OR VENTILATING FAN MUST BE INSTALLED IF ROOM TEMPERATURE EXCEEDS 104 °F.
  - 3) PROVIDE ADEQUATE SPACE DURING INSTALLATION FOR NECESSARY MAINTENANCE AND REPAIRS. ALLOW A MINIMUM OF 20" FROM EACH SIDE OF WALL, AND A MINIMUM OF 20" FROM FRONT OF UNIT, AND A MINIMUM OF 24" FROM TOP OF UNIT.
  - 4) CARE MUST BE TAKEN TO INSURE COMPRESSOR UNIT DOES NOT INTAKE HOT AIR OR DUST.
  - 5) REFER TO INSTRUCTION MANUAL FOR ELECTRIC WIRING DIAGRAM.
  - 6) SPEC IS SUBJECT TO CHANGE WITHOUT NOTICE.

**PROPRIETARY AND CONFIDENTIAL**  
 THE INFORMATION CONTAINED IN THIS DRAWING IS THE SOLE PROPERTY OF ANEST IWATA Air Engineering Inc.. ANY REPRODUCTION IN PART OR AS A WHOLE WITHOUT THE WRITTEN PERMISSION OF ANEST IWATA Air Engineering Inc. IS PROHIBITED.

UNLESS OTHERWISE SPECIFIED:		NAME	DATE	ANEST IWATA Air Engineering Inc.	
DIMENSIONS ARE IN INCHES		DRAWN	AMM		11/6/19
		CHECKED			
		ENG APPR.			
		MFG APPR.			
INTERPRET GEOMETRIC TOLERANCING PER:		Q.A.			
MATERIAL		COMMENTS:			
NEXT ASSY	USED ON	PART NO.	ASSY		
APPLICATION		DO NOT SCALE DRAWING			
SIZE	DWG. NO.	REV			
<b>C</b>	OFT-15(H)-FRD-120				
SCALE: 1:12		WEIGHT:	SHEET 1 OF 1		