



CA72161006

Instruction Manual (Original Instructions)

Oil-free Scroll Vacuum Pump

ISP-1000E

This instruction manual includes very important warnings, cautions and operating procedure in order to operate this pump safely and efficiently. Be sure to read this instruction manual thoroughly and fully understand before operation. After reading it, store it in a convenient place for immediate and future reading.

※Before use, be sure to fill in the blank spaces below for future repair and after-service.

Serial No.
Who sold it to you
Purchase date
When you began operation

UK DECLARATION OF CONFORMITY

Identification of the product : Scroll Vacuum Pump

Name and address of
the manufacturer :

ANEST IWATA Corporation
3176, Shinyoshida-cho, Kohoku-ku,
Yokohama 223-8501,
Japan

Name and address of
the person authorised
to compile the technical file :

Hidetoshi Ishikawa
ANEST IWATA Corporation
3176, Shinyoshida-cho, Kohoku-ku,
Yokohama 223-8501,
Japan

This declaration of conformity is issued under the sole responsibility of the manufacturer.

Object of the declaration :

Series ISP-1000E
Models Designation ISP-1000E-**abc**

a = T , b = H or V , c = S9 , S12 , S34 or blank

Ratings 3-phase, 50Hz, AC200/380/400/415V
 60Hz, AC200/220/230/460V

The object of the declaration described above is in conformity with the relevant
UK harmonisation legislation :

2008 No. 1597 The Supply of Machinery (Safety) Regulations 2008

2012 No. 3032 The Restriction of the Use of Certain Hazardous
 Substances in Electrical and Electronic Equipment
 Regulations 2012

References to the relevant harmonised standards used or references to the specifications
in relation to which conformity is declared :

BS EN 1012-2:1996+A1:2009 Compressors and Vacuum Pumps-Safety Requirements,
 Part 2: Vacuum pumps

BS EN IEC 63000:2018 Technical documentation for the assessment of electrical
 and electronic products with respect to the restriction of
 hazardous substances

Signed for and on behalf of the above named manufacturer :

Place and date of issue : Yokohama, Japan 1-Oct-2022

Name, function : Hitoshi Iwata
 Chief Operating Officer, Air Energy Division

Signature :

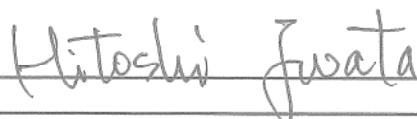

EC DECLARATION OF CONFORMITY

Identification of the product : Scroll Vacuum Pump

Name and address of
the manufacturer :

ANEST IWATA Corporation
3176, Shinyoshida-cho, Kohoku-ku,
Yokohama 223-8501,
Japan

Name and address of
the authorised representative :

ANEST IWATA EUROPE GmbH
Am Stahlbügel 2,
74206 Bad Wimpfen,
Germany

This declaration of conformity is issued under the sole responsibility of the manufacturer.

Object of the declaration :

Series ISP-1000E
Models Designation ISP-1000E-**abc**

a = T , b = H or V , c = S9 , S12 , S34 or blank

Ratings 3-phase, 50Hz, AC200/380/400/415V
60Hz, AC200/220/230/460V

The object of the declaration described above is in conformity with the relevant
EU harmonisation legislation :

2006 / 42 / EC Machinery Directive
2011/65/EU & (EU)2015/863 Restriction of the use of certain Hazardous Substances
in Electrical and electronic equipment

References to the relevant harmonised standards used or references to the specifications
in relation to which conformity is declared :

EN 1012-2:1996+A1:2009 Compressors and Vacuum Pumps-Safety Requirements,
Part 2: Vacuum pumps
EN IEC 63000:2018 Technical documentation for the assessment of electrical
and electronic products with respect to the restriction of
hazardous substances

Name and address of the notified body :

TÜV Rheinland LGA Products GmbH - Tillystraße 2 - 90431 Nürnberg, Germany

Technical Documentation From File No. AM 50332099

Signed for and on behalf of the above named manufacturer :

Place and date of issue : Yokohama, Japan 1-Oct-2022
Name, function : Hitoshi Iwata
Chief Operating Officer, Air Energy Division

Signature :

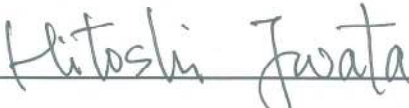

Important information

Be sure to read this instruction manual to understand how to operate the equipment correctly. Only operators, who fully understand warnings, cautions and instructions, are to operate the equipment. Improper operation (mishandling) can cause serious injury, death, fire or explosion.





Store this manual in a convenient place for immediate and future reference.



◆ Regarding safety

- The safety instructions given in this manual are the minimum operating requirements. Follow all national or municipal laws and regulations pertaining to fire, electricity, and other safety regulations, as well as corporate regulations.
- Pay special attention to items which are shown by the below marks and symbols.
- Symbols and marks have the following meanings.

Examples of marks

	WARNING	Indicates a potentially hazardous situation which, if not avoided, may result in serious injury or loss of life.
	CAUTION	Indicates a potentially hazardous situation which, if not avoided, may result in minor or moderate injury or property damage.

Examples of symbols

	Indicates [Beware]. We will explain briefly in or near the symbol. (The example on the left is [Beware of electric shock]).
	Indicates [Prohibited action]. We will explain briefly in or near the symbol. (The example on the left is [Do not touch]).
	Indicates [Required action]. We will explain briefly in or near the symbol. (The example on the left is [Be sure to ground]).

* We will assume no responsibility for any injury or damage caused by disregarding warnings, precautions or instructions.

Supplementary notes







Important	The sign indicates: Please observe these notes and instructions. They are useful to achieve maximum performance and operation lifetime.
------------------	---

For safe operation

Below is very important information in order to safely operate the equipment. Before operation, be sure to read and fully understand the contents.



WARNING

 Be careful about lifting	Danger of cargo collapse Be careful to install vacuum pump using motor eyebolt and crane with sufficient allowable load capacity (ISP-1000E mass 68kgs) while paying attention to stability of suspended load. If not, it can cause damage, failure or injury from falling cargo due to hoisting failure, or by being caught between suspended cargo and other material.	 Avoid moisture	Danger of electric shock Install the unit in an area which is not exposed to moisture such as rain or steam. If moisture comes into and tact with the electric source connection, it can cause fire or injury due to short-circuit or electric shock.
 Install the unit at a safe site	Danger of explosion, fire and accident Install the unit in an area free from explosive, flammable or corrosive substances. If not, it can cause explosion, fire or accident.	 Ask qualified electrician	Danger of short-circuit and electric shock Ask a qualified electrician to perform electric wiring. If not, short-circuit or electric shock can cause fire or injury.
 Turn off electric source	Danger of electric shock and entanglement Be sure to turn off electric source on the installation site before wiring. If not, it can cause electric shock or injury due to turning objects.	 Install overcurrent protective device	Danger of accident, fire and failure Be sure to install protective device to protect circuitry. We recommend overcurrent protective device (rated 15A) to protect branch circuit. If the equipment is not stopped in an emergency, it can cause accident, fire or failure.
 Install emergency stop switch	Danger of accident, fire or failure Be sure to install an electric source emergency stop switch (or protective device that can urgently stop). If the equipment is not stopped in an emergency, it can cause accident, fire or failure.	 Install short circuit protective device	Danger of fire and electric shock Install short circuit protective device. If not, it can cause injury due to fire or electric shock.
 Install motor protective circuit breaker to protect motor	Danger of electric fire and electric shock Install motor protective circuit breaker to protect motor. If not, injury due to electric fire or electric shock can result. If you have any questions about the selection of protective devices, contact either the dealer who sold it to you or us.	 Be careful about wiring	Danger of short-circuit and electric shock We recommend an electric source cable of more than <u>2mm² (more than rated 9A) cross section area for electric source cable and earth cord.</u> Be careful to avoid voltage drop considering local situation. If not, it can cause a short-circuit fire and may result in injury from electric shock.
 Use crimp-style terminal	Danger of short-circuit and electric shock Fit firmly proper round type crimp-style terminal to electric source cable using crimp tool and connect to motor terminal section. If not, it can cause short-circuit fire or injury from electric shock due to looseness or disconnection.	 Protect cable from being pulled	Danger of short-circuit and electric shock Be sure to fit cable-gland to hole of $\phi 22\text{mm}$ at motor terminal box. If not, it can cause short-circuit fire or injury from electric shock.

For safe operation



WARNING



**Protect cable
from being
pulled**

**Danger of short-circuit and
electric shock**

The power-supply conductor shall be free from strain including twisting by using cord anchorage, which is specified by the local electrical wiring regulation.
If not, it can cause short-circuit fire or injury from electric shock.



**Be sure to
ground**

Danger of electric shock

Connect earth cord to earth terminal in motor terminal box.
If not, it can cause injury from electric shock.



**Never evacuate
hazardous gas**

Danger of explosion and ignition

Do not evacuate gas which is hazardous to humans or explosive, flammable, or corrosive. Do not evacuate any gas with substances containing chemicals, solvents, and powders.
If done, it can cause failure or injury by gas, explosion or ignition.



**Avoid foreign
objects**

**Danger of entanglement and
foreign objects dispersal**

Never put finger or foreign objects into air hole of fan cover, air hole of motor or clearance between FS(1) and FS(2) cooling fins.
If done, it can cause injury from entanglement with turning section, or foreign objects dispersal.



**Never make any
modifications**

**Danger of electric shock and
entanglement**

Do not remove or modify safeguards or insulation parts.
If done, it can cause injury from electric shock or turning section and it can cause deteriorated performance and operating lifetime, and invalidate guarantee.



**Change after
vacuum pump is
stopped**

Danger of failure and injury

Change air-flush port only after vacuum pump is stopped.
If you change it during vacuum pump operation, it can cause vacuum pump failure and injury.



**Conduct
periodical
maintenance and
inspection**

Danger of failure and injury

Conduct periodical maintenance and inspection.
If not, it can cause insufficient performance, failure of vacuum pump, and injury.



**Be careful about
high temperature**

Danger of burns

Conduct maintenance and inspection only after vacuum pump becomes cool enough.
Maintenance and inspection soon after vacuum pump stops can cause burn injury.



**Turn off electric
source**

Danger of electric shock

Be sure to conduct maintenance and inspection after you turn off electric source.
If not, it can cause injury from electric shock or turning object.



**Ask specialist to
perform repairs**













**Danger of accident, failure and
shorter operating lifetime**

Ask specialist to perform repairs.
Defective repairs can cause accident, failure or shorter operating lifetime.

For safe operation









CAUTION

 Detach packaging tray	Danger of abnormal vibration Detach equipment from packaging tray. Operation while equipment is mounted on packaging tray can cause abnormal vibration, resulting in accident and failure.	 Use at designated temperature	Danger of overheating Operate at ambient temperature of 10°C~40°C. Operating at a temperature range other than that designated can cause accident, failure or injury such as burns due to overheating.
 Pay attention to ventilation	Danger of overheating Install the unit in a well-ventilated area. Poor ventilation can disrupt cooling and cause accident, failure or injury such as burns since this vacuum pump is an air-cooled type.	 Avoid dust	Danger of dust Be sure site is free from dust. Sucking in of dust can cause failure.
 Install on a solid, level floor	Danger of unbalance Be sure to install on solid and level floor (less than 5° inclination). Uneven installation can cause failure and movement of vacuum pump. If installation floor is unstable, fix pump base with 4 bolts using M10 tap section.	 Avoid direct sunlight	Danger of overheating Install the unit in a place where it is not exposed to direct sunlight. Vacuum pump is exposed to direct sunlight can overheat, resulting in failure.
 Check voltage	Motor burnout Before doing any wiring, check electric source and voltage. Single-phase is a multi voltage type of AC200V/AC400V. <u>Voltage can be changed at terminal block. This pump is wired to 200V when shipping from factory.</u> Check your electric source, voltage, and cord correctly to terminal block. Improper wiring and incorrect voltage can cause motor burnout.	 Inspect cause of problem	Danger of problem recurrence and failure If protective device or thermal protector activates, be sure to turn off electric source and inspect causes to solve the problem. Do not operate until problem is solved. Operation while problem is left unsolved can cause problem recurrence and failure.
 Remove blank flange	Danger of exhaust disruption Remove blank flange from inlet and outlet. Operation with blank flange being fitted can disrupt air flow or cause blank flange to fly by exhaust impetus, resulting in accident, failure, or injury from contact with flying objects.	 Prevent foreign objects from entering	Danger of foreign objects entering inlet When checking turning direction, be careful not to enter foreign objects into an inlet. Foreign objects entering inlet can cause failure.
 Pay attention to exhaust resistance	Danger of exhaust disruption When connecting exhaust piping to vacuum pump and when combining piping with another vacuum pump, pay attention to piping size and length so that it does not cause exhaust resistance. Exhaust resistance can disrupt air flow, resulting in failure and over-current.	 Start or stop after closing isolation valve	Danger of vacuum break and pollution Be sure to close isolation valve between vacuum pump and vacuum system (chamber) during start-up and stop. Start-up or stop with isolation valve in the open position can draw back gas and debris attached to inside of pump to vacuum chamber due to pressure differential, resulting in vacuum break and pollution on vacuum chamber side.



CAUTION

 Open air inlet	<p>Danger of abnormal sound and failure</p> <p>Open inlet to atmosphere for about 5 seconds before restarting vacuum pump. If not, it can unbalance temperature inside vacuum pump, resulting in failure.</p>	 Beware temperature of intake gas	<p>Danger of exceeding permissible temperature of intake gas</p> <p>If intake gas temperature is over 50°C, be sure to install a chiller or trap between vacuum pump and vacuum chamber so that gas intake temperature of vacuum pump keeps below 50°C. If not, vacuum pump temperature can increase, resulting in failure.</p>
 Operate the unit while opening air-flush port	<p>Danger of remaining moisture</p> <p>When evacuating moisture, be sure to open air-flush port (air-flush operation). If you evacuate vapor while air-flush port is closed, condensed water will remain inside vacuum pump and cause failure.</p>	 Caution after exhausting vapor	<p>Danger of insufficient vapor exhaust</p> <p>After evacuating vapor, do air-flush operation for at least one hour. If you close air-flush port or stop vacuum pump soon after evacuating vapor, condensed water will remain inside vacuum pump which will cause failure.</p>
 Beware of intake gas volume	<p>Danger of exceeding permissible intake gas volume</p> <p>When sending N₂ gas or dry air into air-flush port, pressure should be the same as atmospheric pressure and flow rate should be less than 10L/min. If not, it can increase pressure inside vacuum pump, resulting in failure.</p>	 Caution for frequent start/stop and short interval	<p>Risk of motor malfunction</p> <p>Refrain from frequent start/stop operation. It induces malfunction of motor such as burn out. Please consult your dealer or factory representative for details. Appropriate operating mode with adequate interval and frequency of start/stop is varies owing to operating condition.</p>

Where to attach warning stickers

Where to attach warning stickers

Always keep warning stickers clean and legible. If they become dirty or detached, replace them with new ones. If you need replacement stickers, contact the dealer who sold the vacuum pump to you.

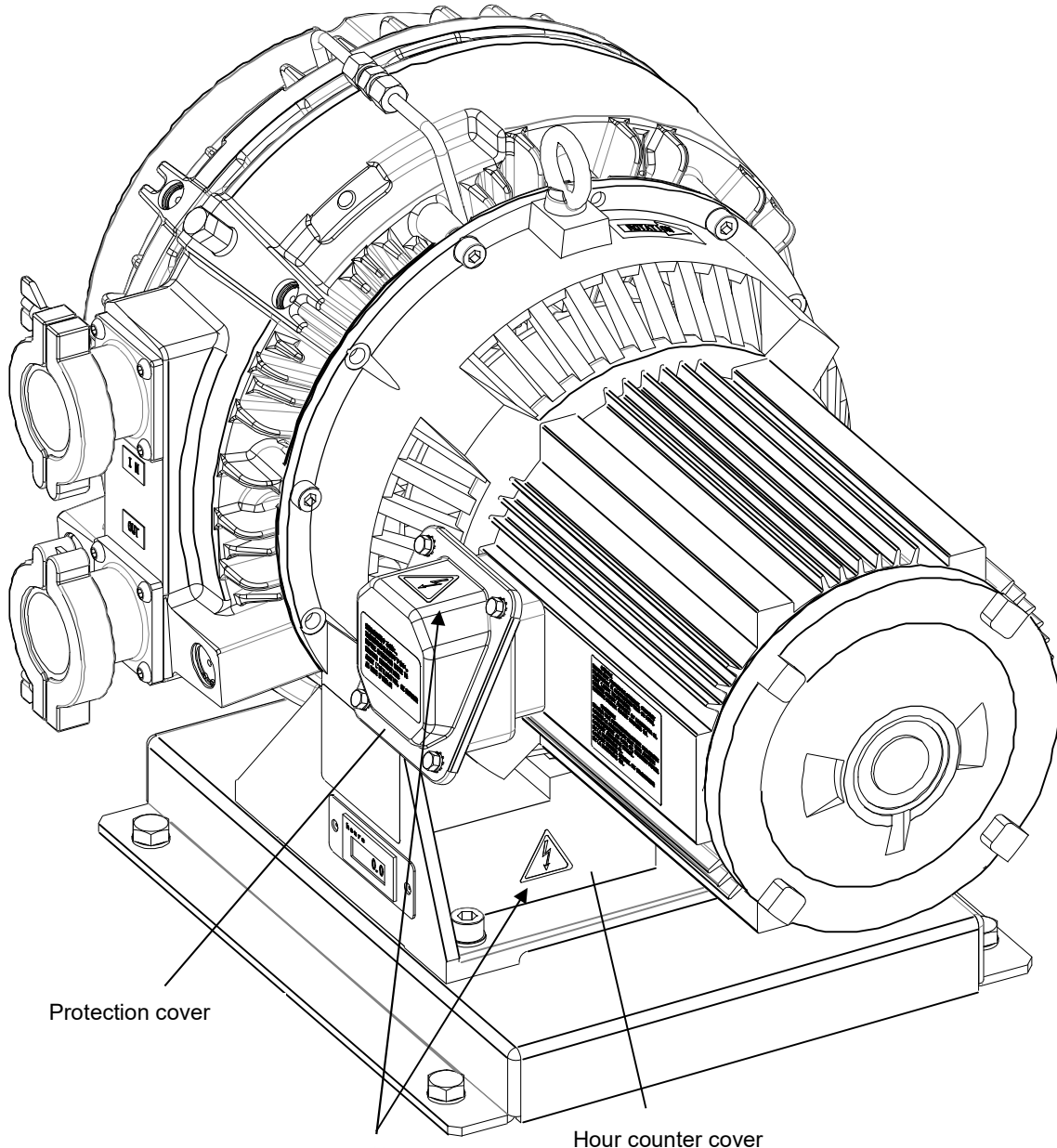

Beware of electric shock

Contents

Important information	1
For safe operation	2
Contents	7
1. Before use	8
1.1 Check the product	8
2. Name and structure of each section	10
3. Installation.....	11
3.1 Wiring.....	12
3.2 Test operation.....	16
3.3 Connection to vacuum system (chamber).....	17
4. Operation.....	18
4.1 Standard operation.....	20
4.1.1 Start-up	20
4.1.2 Shut-down.....	20
4.2 Air-flush operation.....	21
4.2.1 Preparation	21
4.2.2 Start-up and shut-down.....	22
4.2.3 Returning to standard operation.....	22
5. Maintenance and inspection	23
5.1 Daily maintenance and inspection	23
5.2 Maintenance	24
6. Problems and remedies.....	25
7. Disposal.....	25
8. Specifications	26
8.1 Specifications	26
8.2 Dimensions	27
8.3 Performance data	27

1. Before use

1.1 Check the product

- Check that the package is right-side-up before opening.
- Check that the model of the product is the same as the one you ordered.

How to read model name

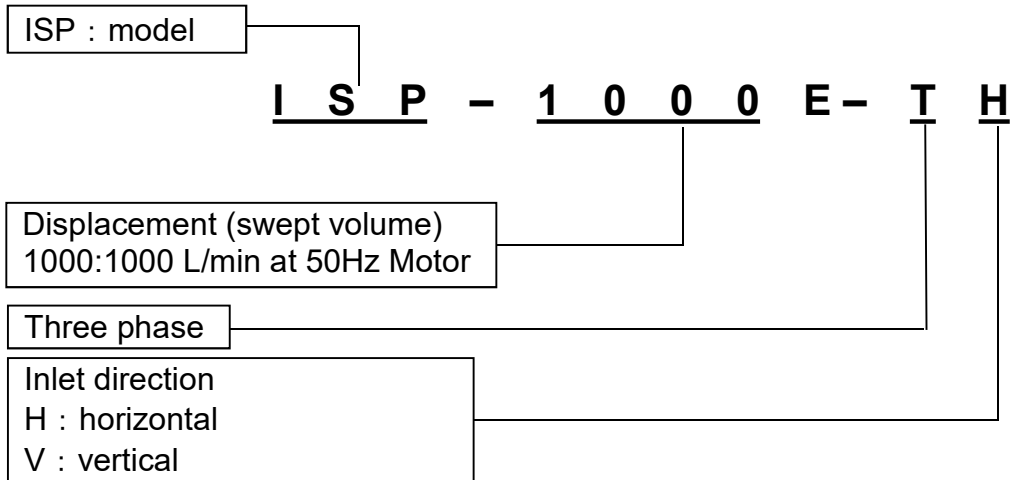

- **Check the unit that there is no damage.**
If there is any damage, contact either the dealer who sold it to you or us.
- **Check the following accessories.**
Instruction manual (this one)
Air muffler for air-flushing (which is attached to eyebolt of motor)

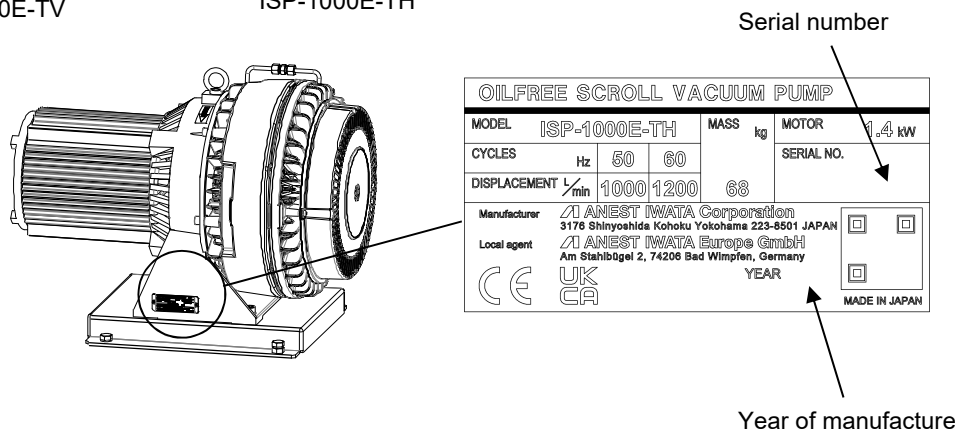
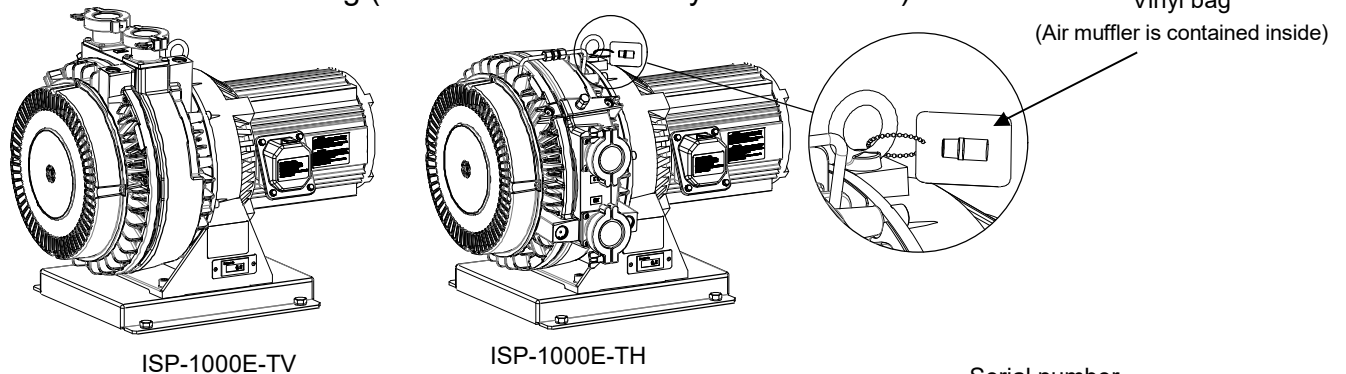

※Please prepare electric source cables, crimp-style terminal, electric source protective devices, piping to inlet, and piping from outlet on customer side.

Open package

	WARNING
---	----------------

Danger of cargo collapse
Be careful to install vacuum pump using motor eyebolt and crane with sufficient allowable load capacity (ISP-1000E mass 68kgs) while paying attention to stability of suspended load.
If not, it can cause damage, failure or injury from falling cargo due to hoisting failure, or by being caught between suspended cargo and other material.

Be careful about hoisting

	CAUTION
---	----------------

Danger of abnormal vibration
Detach equipment from packaging tray.
Operation while equipment is mounted on packaging tray can cause abnormal vibration, resulting in accident and failure.

Detach packaging tray

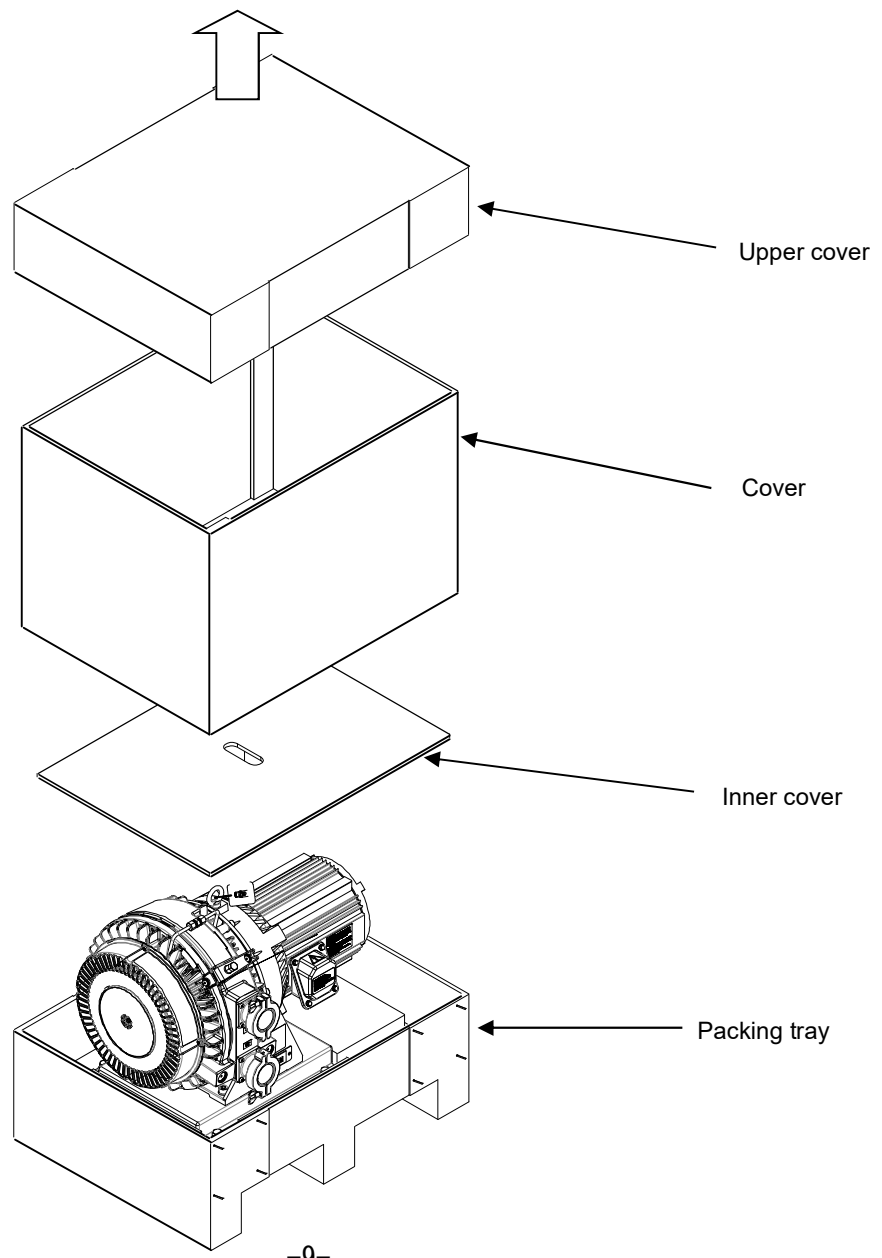



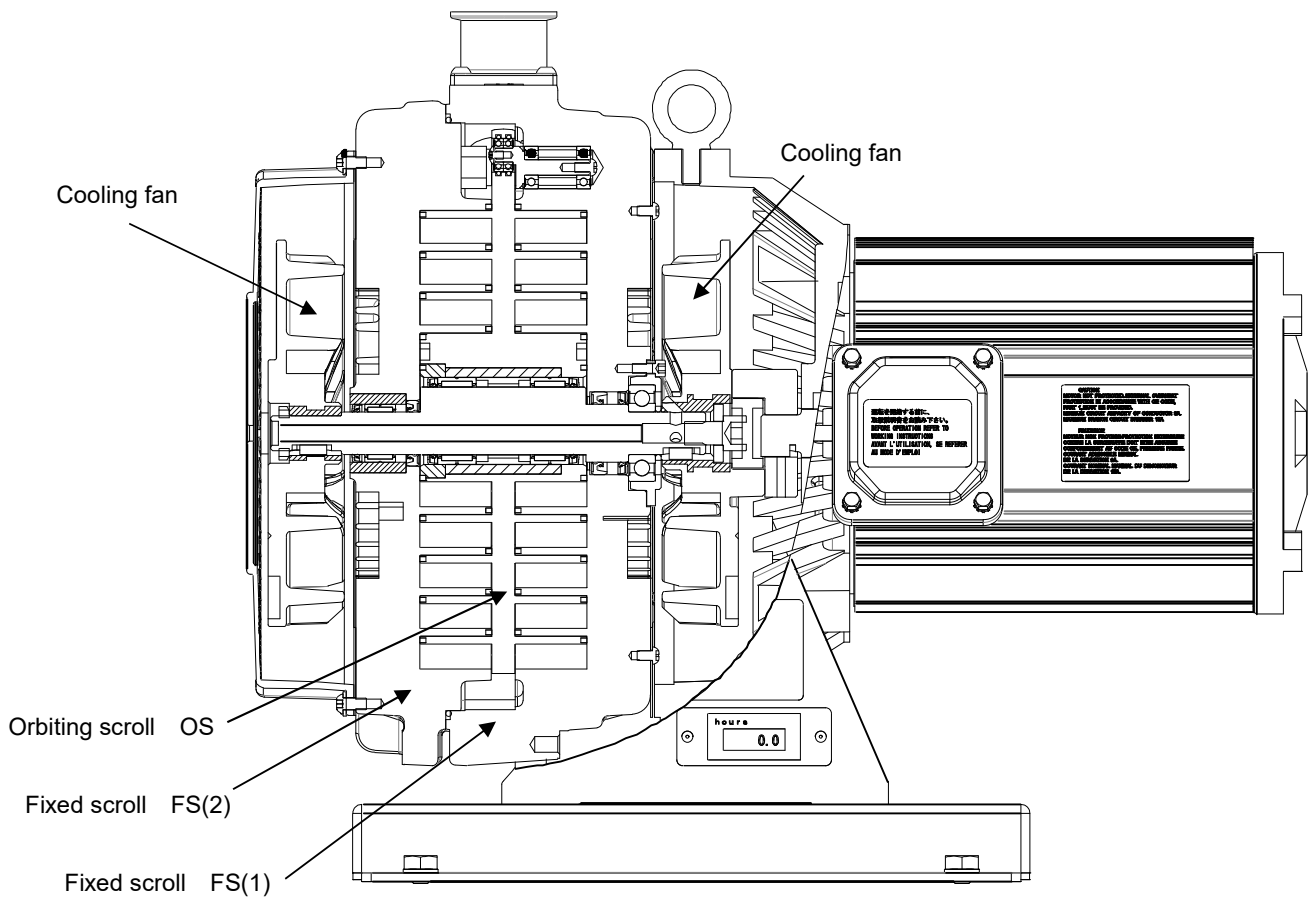
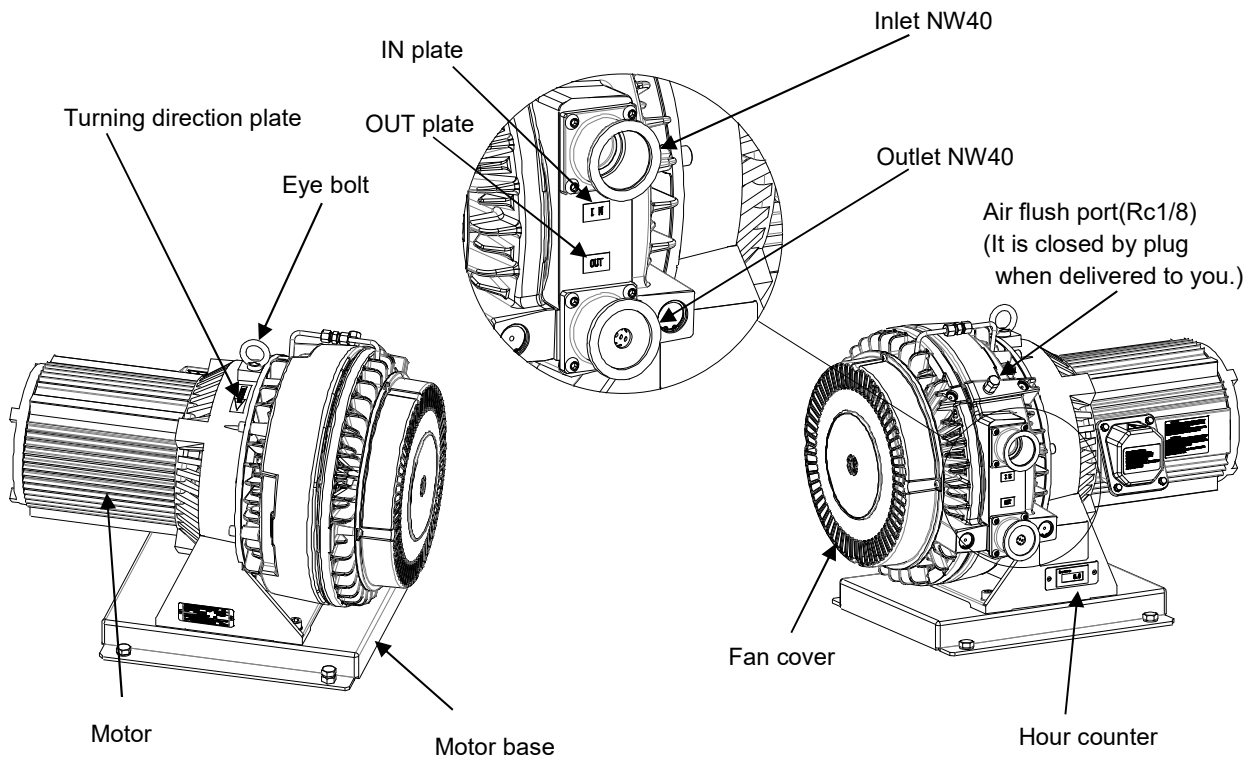







2. Name and structure of each section





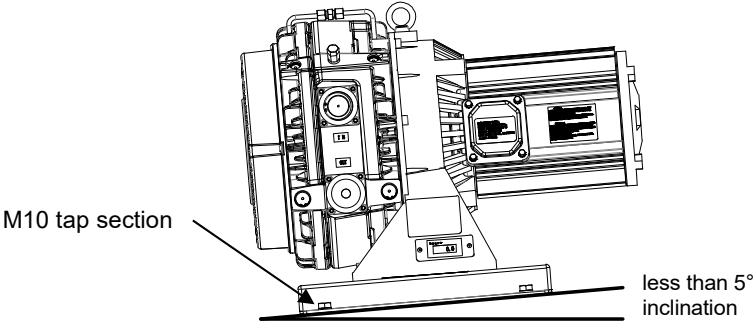









Structure of vacuum pump



3. Installation

 WARNING			
Danger of electric shock Install the unit in an area which is not exposed to moisture such as rain or steam. If moisture comes into and tact with the electric source connection, it can cause fire or injury due to short-circuit or electric shock.	 Avoid moisture		
Danger of explosion, fire and accident Install the unit in an area free from explosive, flammable or corrosive substances. If not, it can cause explosion, fire or accident.	 Install the unit at a safe site		
 CAUTION			
Danger of overheating Operate at ambient temperature of 10°C~40°C. Operating at a temperature range other than that designated can cause accident, failure or injury such as burns due to overheating.	 Use at designated temperature		
Danger of overheating Install the unit in a well-ventilated area (refer to below chart). Poor ventilation can disrupt cooling and cause accident, failure or injury such as burns since this vacuum pump is an air-cooled type.	 Pay attention to ventilation		
<table border="1" style="margin: auto;"> <tr> <td style="padding: 5px;"> Necessary ventilated air volume </td> </tr> <tr> <td style="padding: 5px;"> Over 12m³/min </td> </tr> </table>	Necessary ventilated air volume	Over 12m³/min	
Necessary ventilated air volume			
Over 12m³/min			
Danger of dust Be sure site is free from dust. Sucking in of dust can cause failure.	 Avoid dust		
Danger of unbalance Be sure to install on solid and level floor (less than 5° inclination). Uneven installation can cause failure and movement of vacuum pump. If installation floor is unstable, fix pump base with 4 bolts using M10 tap section.	 Install on a solid, level floor		
			
Danger of overheating Install the unit in a place where it is not exposed to direct sunlight. Vacuum pump is exposed to direct sunlight can overheat, resulting in failure.	 Avoid direct sunlight		
Important			
When building vacuum pump into vacuum system, pay attention to space for maintenance, ambient temperature and piping. Be sure to fix vacuum pump on solid and level floor. If you have any questions, contact the dealer who sold it to you or us.			

3.1 Wiring

 WARNING	
<p>Danger of short-circuit and electric shock</p> <p>Ask a qualified electrician to perform electrical wiring. If not, short-circuit or electric shock can cause fire or injury.</p>	 Ask qualified electrician
<p>Danger of electric shock and entanglement</p> <p>Be sure to turn off electric source on the installation site before wiring. If not, it can cause electric shock or injury due to turning objects.</p>	 Turn off electric source
<p>Danger of accident, fire and failure</p> <p>Be sure to install protective device to protect circuitry. We recommend overcurrent protective device (rated 15A) to protect branch circuit. If the equipment is not stopped in an emergency, it can cause accident, fire or failure.</p>	 Install overcurrent protective device
<p>Danger of accident, fire or failure</p> <p>Be sure to install an electric source emergency stop switch (or protective device that can urgently stop). If the equipment is not stopped in an emergency, it can cause accident, fire or failure.</p>	 Install emergency stop switch
<p>Danger of fire and electric shock</p> <p>Install short circuit protective device. If not, it can cause injury due to fire or electric shock.</p>	 Install short circuit protective device
<p>Danger of electric fire and electric shock (refer to chart 1 on page 14)</p> <p>Install motor protective circuit breaker to protect motor. If not, injury due to electric fire or electric shock can result. If you have any questions about the selection of protective devices, contact either the dealer who sold it to you or us.</p>	 Install motor protective circuit breaker to protect motor
<p>Danger of short-circuit and electric shock</p> <p>We recommend an electric source cable of more than <u>2mm² (more than rated 9A) cross section area for electric source cable and earth cord.</u> Be careful to avoid voltage drop considering local situation. If not, it can cause a short-circuit fire and may result in injury from electric shock.</p>	 Be careful about wiring
<p>Danger of short-circuit and electric shock</p> <p>Fit firmly proper round type crimp-style terminal to electric source cable using crimp tool and connect to motor terminal section. If not, it can cause short-circuit fire or injury from electric shock due to looseness or disconnection.</p>	 Use crimp-style terminal
<p>Danger of short-circuit and electric shock</p> <p>Be sure to fit cable-gland to hole of ϕ 22mm at motor terminal box. If not, it can cause short-circuit fire or injury from electric shock.</p>	 Protect cable from being pulled
<p>Danger of short-circuit and electric shock</p> <p>The power-supply conductor shall be free from strain including twisting by using cord anchorage, which is specified by the local electrical wiring regulation. If not, it can cause short-circuit fire or injury from electric shock.</p>	 Protect cable from being pulled

<p>Danger of electric shock Connect earth cord to earth terminal in motor terminal box. If not, it can cause injury from electric shock.</p>	 Be sure to ground
<p>Canadian regulation Motor not protected. External overheat protection in accordance with Canadian Electric Code Part I [C22.1], must be provided. Min. circuit ampacity of conductor is 9A Max. branch circuit breaker is 15A</p> <p>When you used this pump in Europe or UK. This vacuum pump must be equipped with a main disconnect device in accordance with requirements of EN/BS EN 60204-1, clause 5.3.2. It is recommended to use a circuit breaker as main breaker which is suitable for isolation according to EN/BS EN 60947-2 and is equipped with an operating handle which is lockable in OFF position and complies with the other requirements of EN/BS EN 60204-1, clause 5.3.</p>	

 CAUTION	
<p>Motor burnout Before doing any wiring, check electric source and voltage. This pump is a multi voltage type of AC200V/AC400V. <u>Voltage can be changed at terminal block.</u> <u>This pump is wired to 200V when shipping from factory.</u> Check your electric source, voltage, and cord correctly to terminal block. Improper wiring and incorrect voltage can cause motor burnout.</p>	 Check voltage
<p>Danger of problem recurrence and failure If protective device activates, be sure to turn off electric source and inspect causes to solve the problem. Do not operate until problem is solved. Operation while problem is left unsolved can cause problem recurrence and failure.</p>	 Inspect cause of problem

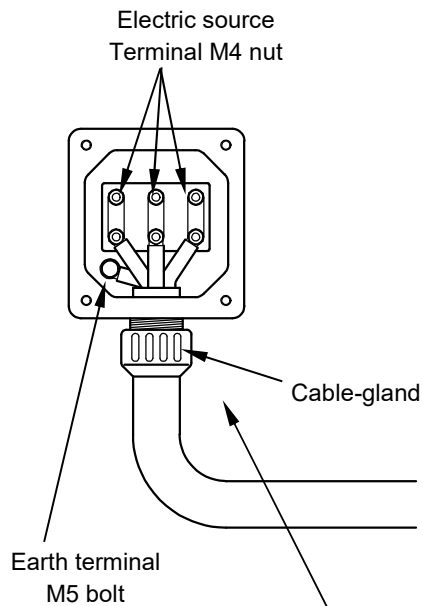

Activate the emergency stop by electric source switch or protective device.



Avoid motor burnout by protective device (chart 1).



Use rated over 9A electric source cable and earth cord.



Use round type terminal.



Fit cable-gland.



Connect earth cord to earth terminal.

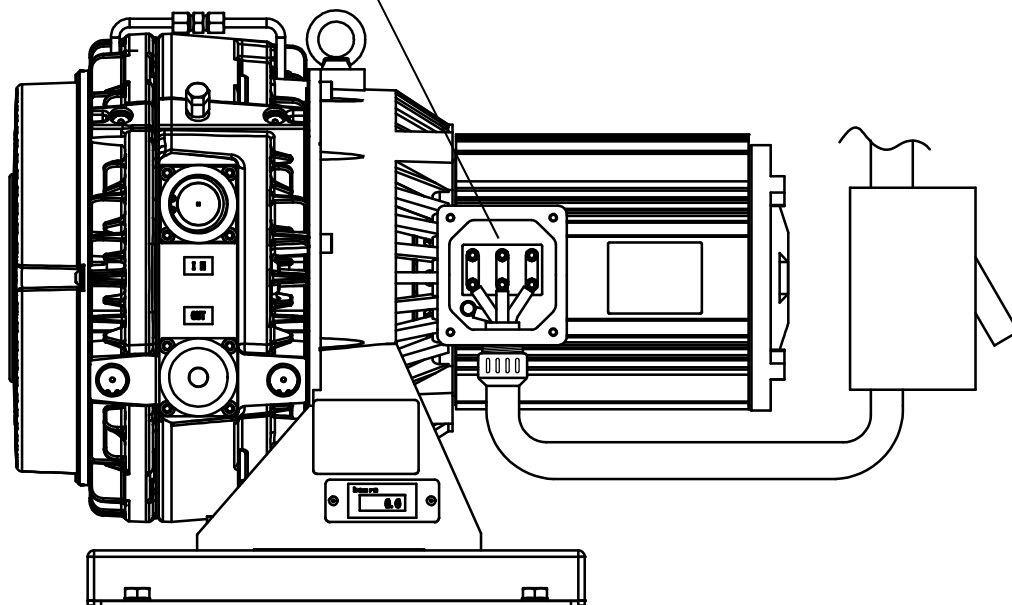
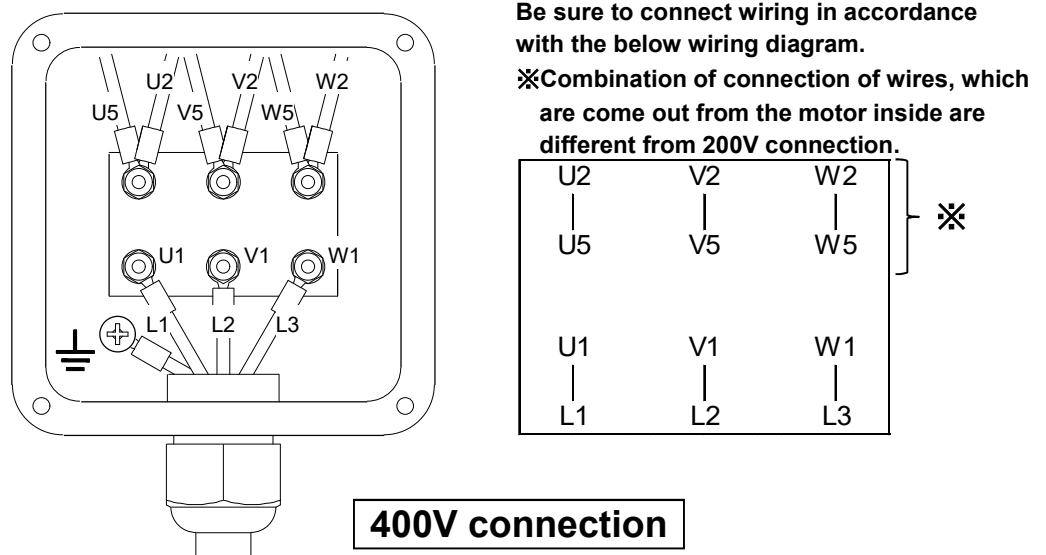
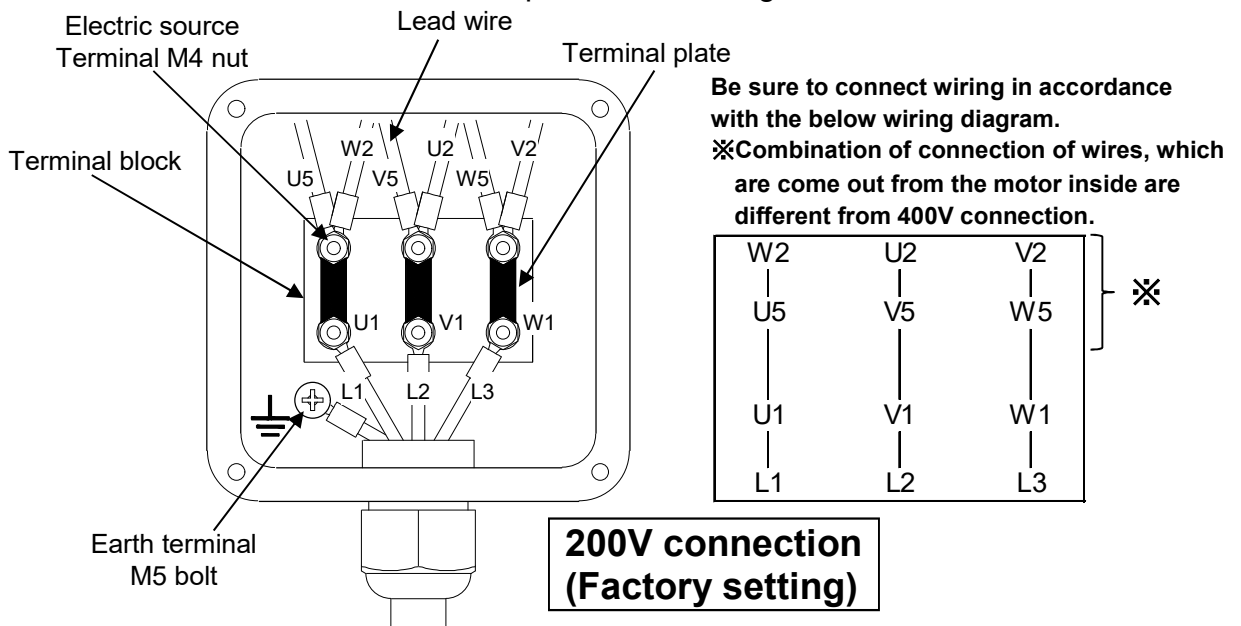

Chart-1



Voltage V	Frequency Hz	Recommended protective device (or breaker) capacity A
200	50	7.6
200	60	6.7
220	60	6.7
230	60	6.7
380	50	3.7
400	50	3.8
415	50	3.8
460	60	3.3

How to wire

- ① Remove 4pcs. of M5 bolts at motor terminal box and remove protection cover.
 ※Be sure to keep M5 bolts and washer, which were removed from the protection cover.
- ② Wiring diagram is shown inside protection cover.
 You can change to a 200V or 400V connection by changing terminal plate (3pcs.) and lead wire connection.
- ※**It is wired to 200V when shipping from factory.**
- ③ If you want to change to a 400V connection, change terminal plate and lead wire connection as illustrated below.
 ※Never lose terminal plates. They will be required for altering wiring connection to 200V.
- ④ Connect electric cable to terminal by using cable-gland at $\phi 22\text{mm}$ hole of motor terminal box.
- ⑤ Insert electric source cable through cable-gland on the bottom side of terminal box.
- ⑥ Connect each phase L1-L2-L3 to each electric source terminal respectively in accordance with the below wiring diagram.
 Terminal screw nuts should be torqued between $1.2\text{ N} \cdot \text{m}$ and $1.5\text{ N} \cdot \text{m}$.
- ⑦ The protective earth cord shall suffice in length and put up to keep the cord the last to take the strain if the cable slips in its anchorage.



3.2 Test operation

 CAUTION	
<p>Danger of exhaust disruption</p> <p>Remove blank flange from inlet and outlet.</p> <p>Operation with blank flange being fitted can disrupt exhaust or cause blank flange to fly by exhaust impetus, resulting in accident, failure, or injury from contact with flying objects.</p>	 <p>Remove blank flange</p>
<p>Danger of foreign objects entering inlet</p> <p>When checking turning direction, be careful not to enter foreign objects into an inlet.</p> <p>Foreign objects entering inlet can cause failure.</p>	 <p>Prevent foreign objects from entering</p>

Test operation

- ① Open inlet and outlet
Remove blank flanges (2 places)
from inlet and outlet of vacuum pump.

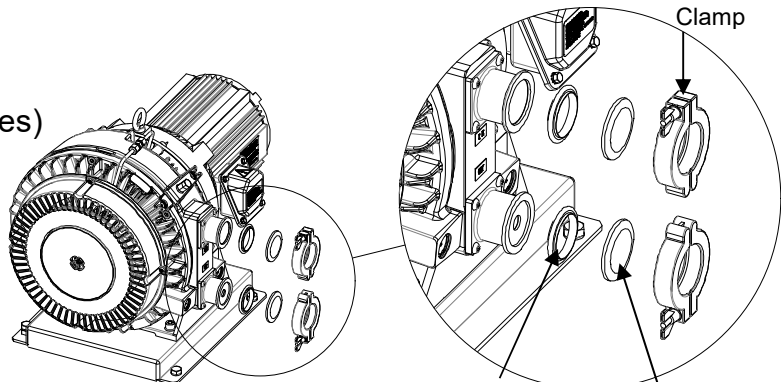

- ② Check turning direction
Open inlet, turn on electrical source
to start operating vacuum pump.
Vacuum pump turns clockwise
when viewed from motor side.

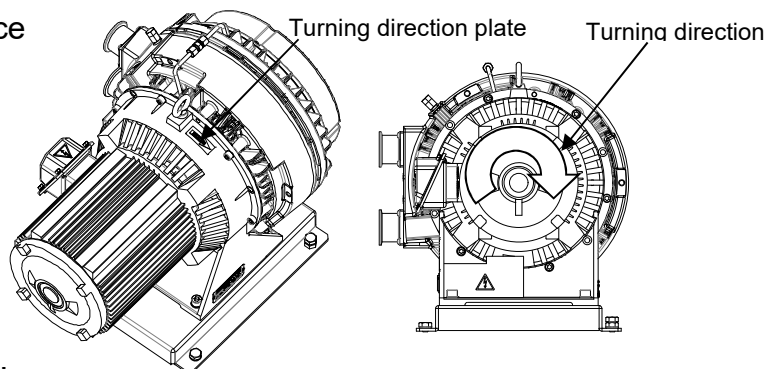

Check that comes out of air outlet.

If air does not come out from outlet, vacuum pump may turn in reverse.

In that case, stop vacuum pump, turn off main electrical source and change 2 out of 3 cords of electric source connection and change turning direction to correct one.

If you install pump to vacuum system and control operation of vacuum pump by remote control, **first check pump itself for turning direction** and then install it to vacuum system.

Important



Vacuum pump turns clockwise when viewed from motor side.

Check that air comes out from outlet.

If pump turns counter-clockwise, stop vacuum pump, turn off electrical source and change 2 out of 3 cords of electrical source connection.

3.3 Connection to vacuum system (chamber)

Inlet is NW40 and outlet is NW40.

 CAUTION	
Danger of exhaust disruption When connecting exhaust piping to vacuum pump and when combining piping with another vacuum pump, pay attention to piping size and length so that it does not cause exhaust resistance. Exhaust resistance can disrupt air flow, resulting in failure and over-current.	 Pay attention to exhaust resistance

Important

Use isolation valve between vacuum system and inlet.

Isolation valve is necessary to prevent the drawback of debris attached to the inside of vacuum pump into the vacuum chamber during start-up and shut-down. (We also recommend the use of leak valve). We recommend the use of an automatic valve as the isolation valve which closes during power failure in order to prevent the drawback of debris inside pump into the vacuum chamber.

Use the clean connecting pipe between vacuum chamber and vacuum pump.

We recommend the use of a flexible tube between inlet of vacuum pump and vacuum chamber so that vibration of pump does not transmit to vacuum chamber.

When connecting exhaust piping to outlet of vacuum pump, refer to the following size and length.

- max. 40m direct pipe length for exhaust pipe size NW40 (inner dia.40 mm)

But if pipe length becomes longer, use a larger size exhaust pipe.

Make sure that exhaust piping is not clogged during pump operation.

Make sure that pressure at outlet does not exceed atmospheric pressure at any conditions.

In order to keep condensation away from feeding into the exhaust port, take proper measure.



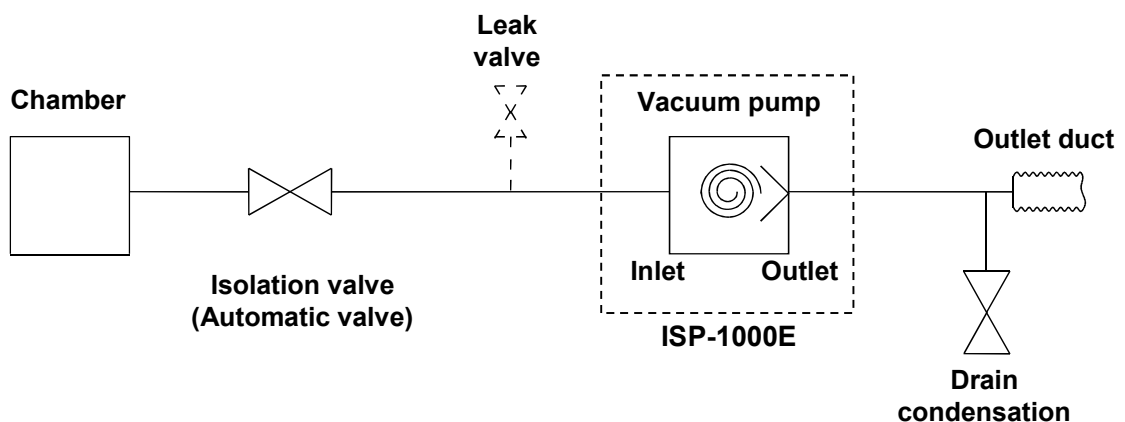



It causes exhaust disturbance. Drain condensations periodically by using valve separately arranged.



4. Operation

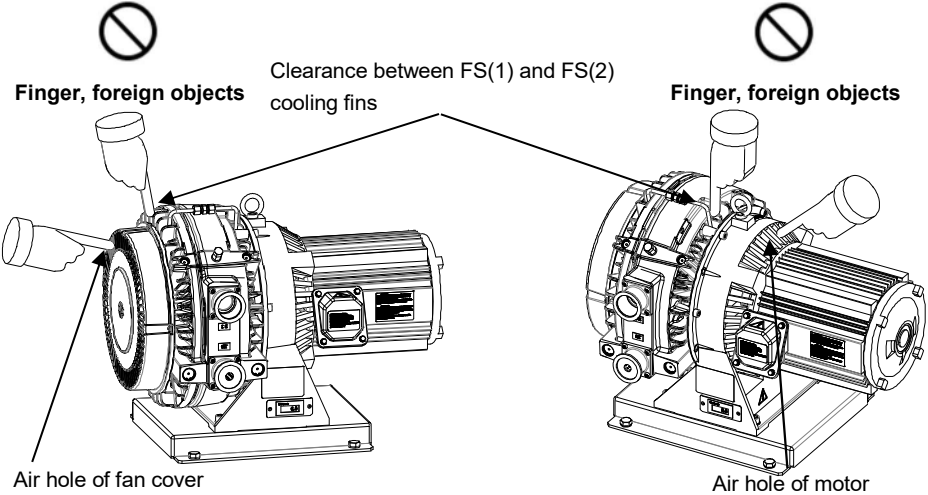







Be sure to use the procedure below to start up or shut down the pump.

- When you do not use air-flush device, **proceed 4.1 Standard operation [page 20].**
- When you use air-flush device, **proceed 4.2 Air-flush operation [page 21].**

 WARNING	
<p>Danger of explosion and ignition</p> <p>Do not evacuate gas which is hazardous to humans or explosive, flammable, or corrosive. Do not evacuate any gas with substances containing chemicals, solvents, and powders.</p> <p>If done, it can cause failure or injury by gas, explosion or ignition.</p> <div style="border: 1px solid black; padding: 5px; margin: 10px 0;"> <p style="text-align: center;"> Do not pump</p> <ul style="list-style-type: none"> · Toxic gas · Explosive gas · Flammable gas · Corrosive gas · Chemicals · Solvent · Powder · Water · Liquid </div> <p>※When evacuating vapor, operate in accordance with 4.2 [page 21].</p>	 Never evacuate hazardous gas
<p>Danger of entanglement and foreign objects dispersal</p> <p>Never put finger or foreign objects into air hole of fan cover, air hole of motor or clearance between FS(1) and FS(2) cooling fins.</p> <p>If done, it can cause injury from entanglement with turning section, or foreign objects dispersal.</p> <div style="text-align: center; margin: 10px 0;">  </div>	 Avoid foreign objects
<p>Danger of electric shock and entanglement</p> <p>Do not remove or modify safeguards or insulation parts.</p> <p>If done, it can cause injury from electric shock or turning section and it can cause deteriorated performance and operating lifetime, and invalidate guarantee.</p>	 Never make any modifications
<p>Danger of failure and injury</p> <p>Change air-flush port only after vacuum pump is stopped.</p> <p>If you change it during vacuum pump operation, it can cause vacuum pump failure and injury.</p>	 Change after vacuum pump is stopped



CAUTION

<p>Danger of exhaust disruption</p> <p>Remove blank flange from inlet and outlet. Operation with blank flange being fitted can disrupt exhaust or cause blank flange to fly by exhaust impetus, resulting in accident, failure, or injury from contact with flying objects.</p>	 Remove blank flange
<p>Danger of vacuum break and pollution</p> <p>Be sure to close isolation valve between vacuum pump and vacuum system (chamber) during start-up and stop. Start-up or stop with isolation valve in the open position can draw back gas and debris attached to inside of vacuum pump to vacuum chamber due to pressure differential, resulting in vacuum break and pollution on vacuum chamber side.</p>	 Start or stop after closing isolation valve
<p>Danger of abnormal sound and failure</p> <p>Open inlet to atmosphere for about 5 seconds before restarting vacuum pump. If not, it can unbalance temperature inside vacuum pump, resulting in failure.</p>	 Open air inlet
<p>Danger of exceeding permissible temperature of intake gas</p> <p>If intake gas temperature is over 50°C, be sure to install a chiller or trap between vacuum pump and vacuum chamber so that gas intake temperature of vacuum pump keeps below 50°C. If not, vacuum pump temperature can increase, resulting in failure.</p>	 Beware temperature of intake gas
<p>Danger of remaining moisture</p> <p>When evacuating moisture, be sure to open air-flush port (air-flush operation). If you evacuate vapor while air-flush port is closed, condensed water will remain inside vacuum pump and cause failure.</p>	 Operate the unit while opening air-flush port
<p>Danger of insufficient vapor exhaust</p> <p>After evacuating vapor, do air-flush operation for at least one hour. If you close air-flush port or stop vacuum pump soon after evacuating vapor, condensed moisture will remain inside vacuum pump, which will cause failure.</p>	 Caution after exhausting vapor
<p>Danger of exceeding permissible intake gas volume</p> <p>When sending N₂ gas or dry air into air-flush port, pressure should be the same as atmospheric pressure and flow rate should be less than 10L/min. If not, it can increase pressure inside vacuum pump, resulting in failure.</p>	 Beware of intake gas volume
<p>Risk of motor malfunction</p> <p>Refrain from frequent start/stop operation. It induces malfunction of motor such as burn out. Please consult your dealer or factory representative for details. Appropriate operating mode with adequate intervals and frequency of start/stop is varies owing to operating conditions.</p>	 Caution for frequent start/stop and short interval

Important

If it takes time to reach ultimate pressure of pump during initial operation (also operation after pump has not been used for a long time),

Close inlet, and continue operation for 6~8 hours while opening inlet for 3~5 seconds to atmosphere 2~3 times per hour. During pump stoppage, moisture might have entered inside of pump and deteriorated performance to reach ultimate pressure.

If pump has evacuated liquid such as water or high humid air (over 60%RH),

Moisture can deposit inside pump and cause pump failure. In that case, close isolation valve, and open inlet to atmosphere for 3~5 seconds several times and exhaust moisture inside pump to outside.

If pump has continued operation around ultimate pressure or continuously evacuated high humid gas

Moisture can be condensed and remain inside pump, causing insufficient ultimate pressure and failure.

In that case, do air-flush operation in accordance with 4.2 [page 21].

4.1 Standard operation

4.1.1 Start-up

- ① Check that blank flange of outlet have been removed.
- ② Close isolation valve in order to prevent the drawback of debris attached to the inside of vacuum pump into vacuum chamber due to pressure differential, resulting in vacuum break and pollution.
(Open leak valve if you use leak valve).
- ③ Turn on vacuum pump.
Please install an external power switch or protective device (breaker) before letting vacuum pump operate.
- ④ Check start-up of vacuum pump and open isolation valve (close leak valve soon after start-up if you use leak valve) and evacuate vacuum chamber.

Important

When continuously operating pump at around ultimate pressure (for example, using as fore line pump of turbo molecular pump) ,

It can cause foreign objects or moisture to deposit inside pump, resulting in failure.

In that case, do air-flush operation or close isolation valve and open inlet to atmosphere for 3~5 seconds, 3~5 times daily.

Be careful not to damage air-flush port (especially air-muffler section).

If not, it can cause failure.

When doing air-flush operation,

Noise level will increase (by 7~8dB).

Install pump in an area which is not exposed to debris such as iron powder, stone powder, polish powder or wood dust.

Debris can clog air-muffler, undercutting air-flush effect.

4.1.2 Shut-down

- ① Be sure to close isolation valve in order to prevent the drawback of debris attached to inside of vacuum pump into vacuum chamber during operation due to pressure differential (open leak valve if you use leak valve).
- ② Turn off vacuum pump.
Please install an external power switch or protective device (breaker) before letting vacuum pump operate.
- ③ Check shut-down of vacuum pump.

Important

Be sure to close isolation valve between vacuum pump and vacuum chamber during pump shut-down.

If vacuum pump stops during air-flush operation, atmospheric air is drawn back from air-flush port to inside of vacuum pump, and vacuum on chamber side cannot be maintained. Be sure to close isolation valve between vacuum pump and vacuum chamber to prevent the drawback of debris from vacuum pump into vacuum chamber before stopping vacuum pump.

When returning air-flush operation to standard operation, operate as per 4.2.3[page 22].

4.2 Air-flush operation

This pump is equipped with air-flush port. Before evacuating vapor, read precautions below completely and be sure to understand the contents.

Purpose of air-flush

Processing humid air by vacuum pump may cause condensed water to remain in pump. This remaining condensation will cause a failure of ultimate pressure of pump. Air-flush operation will contribute to remove the remaining condensation inside. Air-flush operation does not only remove condensation but also restores ultimate pressure.

- ※Continuous operation with the air flush function does not affect performance of the vacuum pump.
- ※Vapor disposal volume is max. 25g/day when doing air-flush operation (ambient temperature 25°C, humidity 60%RH).

Important

Maintenance interval of this pump is based on clean gas applications The standard differs when evacuating vapor.

You must shorten maintenance interval (5.2[page 24]) when evacuating vapor since vapor temperature, disposal volume, disposal frequency and substances in vapor have an influence on pump operation. When evacuating vapor, pay attention to all WARNING, CAUTION and Important notes (4 [page 18~19]).

4.2.1 Preparation

Before starting air-flush operation, first stop vacuum pump and proceed in accordance with the following procedure. Never try to do air-flush operation during operation.

Fit air-muffler

- ① Stop vacuum pump.
 - ② Remove plug from air-flush port with a spanner (nominal dia. 13mm).
- ※The pipes are not for Air Flush. Do not loosen screw nuts.
 - ③ Lightly fit the attached air-muffler to air-flush port.
 - ※Store the removed plug and do not misplace it.

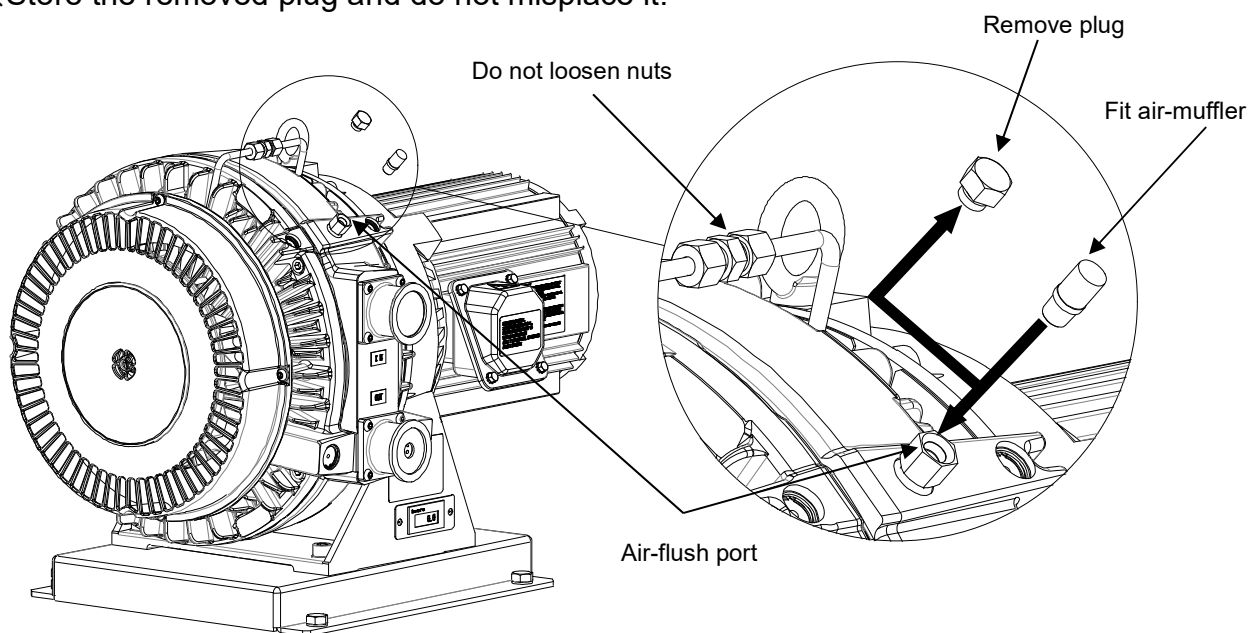

4.2.2 Start-up and shut-down

- ① Start vacuum pump according to 4.1.1 Start-up [page 20].
- ② Stop vacuum pump according to 4.1.2 Shut-down [page 20].

Important

Continuous evacuating of humid gas

When evacuating vacuum chamber while humidity in chamber is high, moisture volume drawn into pump differs according to temperature and pressure in chamber.

When pumping vacuum chamber containing humid gas, be sure to open air-flush port and operate pump (air-flush operation).

Be careful not to damage air-flush port (especially air-muffler section).

Damage to air-flush port can cause failure.

When doing air-flush operation

Noise level will increase (by 7~8dB).

Install pump in an area which is not exposed to debris such as iron powder, stone powder, polish powder or wood dust.

Debris can clog air-muffler, undercutting air-flush effect.

Be sure to close isolation valve between vacuum pump and vacuum chamber during pump shut-down.

If vacuum pump stops during air-flush operation, atmospheric air is drawn back from air-flush port to inside of vacuum pump, and vacuum on chamber side cannot be maintained. Be sure to close isolation valve between vacuum pump and vacuum chamber to prevent the drawback of debris from vacuum pump into vacuum chamber before stopping vacuum pump.

When operating with air-flush OFF (closed), operate as per 4.2.3 [page 22].

4.2.3 Returning to standard operation



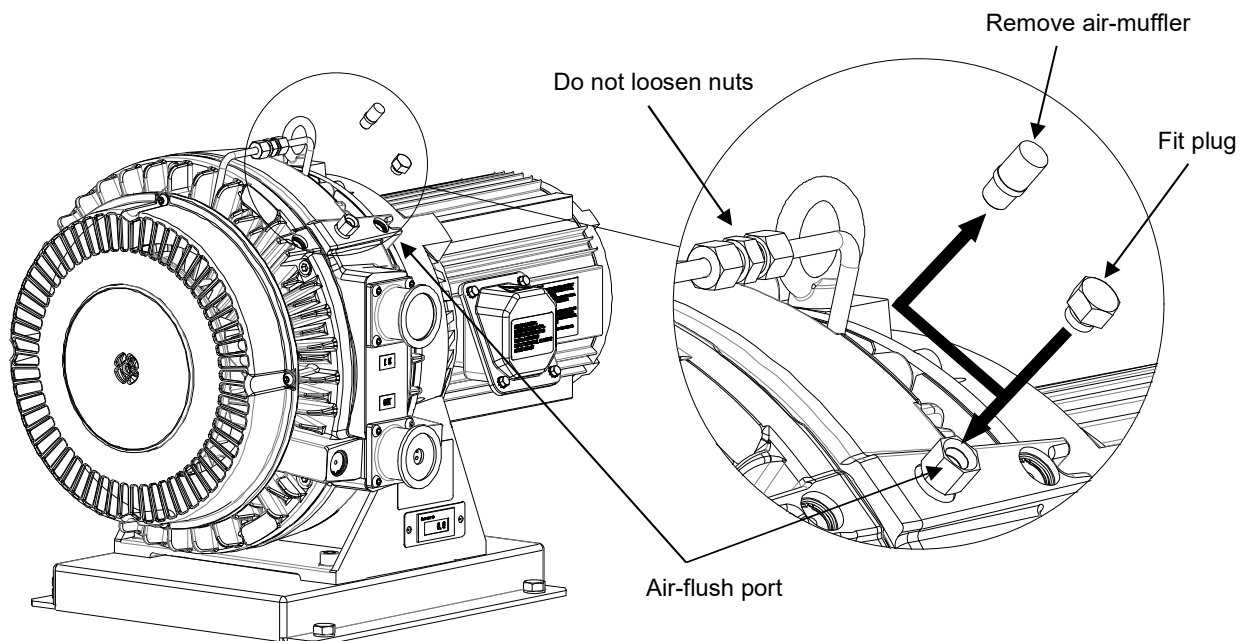

Before starting air-flush operation, first stop vacuum pump and proceed in accordance with the following procedure. Never perform this procedure during operation.

Remove air-muffler

- ① Stop vacuum pump.
 - ② Remove air muffler from air-flush port.
 - ③ Lightly fit plug to air-flush port with a spanner (nominal dia. 13mm).
- ※When restarting air-flush operation, refer to 4.2.1~4.2.2 [page 21~22] and prepare and start.
- ※Store removed air muffler and pay attention not to misplace it.



5. Maintenance and inspection

 WARNING	
<p>Danger of failure and injury</p> <p>Conduct periodical maintenance and inspection. If not, it can cause insufficient performance, failure of vacuum pump, and injury.</p>	 Conduct periodical maintenance and inspection
<p>Danger of burns</p> <p>Conduct maintenance and inspection only after vacuum pump becomes cool enough. Maintenance and inspection soon after vacuum pump stops can cause burn injury.</p>	 Be careful about high temperature
<p>Danger of electric shock</p> <p>Be sure to conduct maintenance and inspection after you turn off electric source. If not, it can cause injury from electric shock or turning object.</p>	 Turn off electric source
<p>Danger of accident, failure and shorter operating lifetime</p> <p>Ask specialist to perform repairs. Defective repairs can cause accident, failure or shorter operating lifetime.</p>	 Ask specialist to perform repairs

5.1 Daily maintenance and inspection

Conduct the following daily maintenance and inspection.

Items	Contents	Measures
Vacuum pump itself	Abnormal sound	Ask specialist to repair.
	Abnormal vibration	Ask specialist to repair.
	Abnormal temperature	Ask specialist to repair.
	Cooling fins are dirty or clogged	Blowing air, cleaning
Cooling fan Fan cover	Abnormal rotation	Ask specialist to repair.
	Dirty, clogged, damaged	Blowing air, cleaning, ask specialist to repair.
Air muffler	Dirty, clogged	Replace
Electric source cable	Deteriorated	Replace

5.2 Maintenance

When maintenance interval has elapsed, be sure to contact our dealer who sold the pump to you. This vacuum pump requires maintenance conducted only by our authorized specialist. Never try to disassemble, reassemble or modify on user's side. We are not responsible for any accidents caused by disassembly, reassembly or alteration which was done by the user or non-specialist.

The following parts are consumable and need to be replaced periodically. Whenever something goes wrong with them, replace them immediately.

Where to inspect	Maintenance interval		Every 400 times vapor pumping
	Yearly or every 8,000 hours	Biennially or every 16,000 hours	
Bearing kit	Grease / Δ	○	Δ
Tip seal set	○	○	Δ
Seal set	○	○	Δ
O-ring set	○	○	Δ
Exhaust valve set	○	○	Δ
Air-flush kit	○	○	○
Pin crank kit	Δ	Δ	Δ
Stopper set	Δ	○	Δ
Vacuum pump itself	Inside cleaning / Δ	Inside cleaning / Δ	Inside cleaning / Δ

○ . . . Replace

Δ . . . Replace if something goes wrong.

Note 1 : Maintenance interval should be shorter than either the period or operating hours.

Note 2 : When you want further maintenance and inspection after either the 6th year or 48,000 operating hours, please contact our dealer who sold the pump to you.

Important

Causes of failure

Shorten maintenance interval if conditions of installation or operation are unfavorable.

In particular, ambient temperature has a great influence on failure. Maintenance interval is based on an ambient temperature 10~40°C and a yearly average ambient temperature 25°C.

Shorten the maintenance interval if temperature exceeds the foregoing. If not, it can cause failure.

Maintenance interval is not a guarantee period.

Exceeding maintenance interval

Operation exceeding maintenance interval increases risk of failure and accidents.

When maintenance interval has elapsed, be sure to contact either the dealer who sold it to you or us.

6. Problems and remedies

If something goes wrong, refer to the following chart and remedy problems.

If you cannot solve your problems, please contact either our dealer who sold it to you or us.

Problems	Causes	Remedies
Motor does not rotate.	Protective device (or breaker) activates.	Check protective device (or breaker) capacity. ※Inspect and repair.
	Electric source cable is loose or cut.	Check connection. Repair or replace.
	Voltage drops.	Check size and length of cable.
	Motor malfunctions.	※Inspect and repair.
	Pump malfunctions. Foreign objects enters.	※Inspect and repair.
	Motor protection gear activates.	Air outlet is clogged. Reset thermal protector. ※Inspect and repair.
Motor stops soon.	Protective device (or breaker) activates.	Check protective device (or breaker) capacity. ※Inspect and repair.
	Voltage drops.	Check size and length of cable.
	Motor malfunctions.	※Inspect and repair.
	Pump malfunctions. Foreign objects enters.	※Inspect and repair.
	Improper exhaust piping.	Check exhaust piping diameter and length. Air outlet is clogged. Remove blank flange from exhaust outlet.
	Motor protection gear activates.	Air outlet is clogged. Reset thermal protector. ※Inspect and repair.
Ultimate pressure is insufficient.	Air leaks from piping. O-ring is damaged.	Check tightness of piping. Replace.
	Moisture and solvent are drawn.	Open inlet to atmosphere and operate for a few minutes and then close inlet and operate for about 24 hours. Do air-flush operation. Install trap and filter.
	Number of motor revolutions drops.	Check wiring and voltage. ※Inspect and repair.
	Pump malfunctions.	※Inspect and repair.
Abnormal sound, abnormal vibration	Connection becomes loose.	Tighten connection. ※Inspect and repair.
	The installation is not level.	Correct vacuum pump inclination within 5°. ※Inspect and repair.
	Foreign objects enters pump.	※Inspect and repair.
	Motor malfunctions.	※Inspect and repair.
	Pump malfunctions.	※Inspect and repair.

※ Contact our dealer who sold the pump to you.

7. Disposal

When a vacuum pump is disposed, please comply with local law and/or regulations such as the Waste Disposal Law.

8. Specifications

8.1 Specifications

Model		ISP-1000E-TH			ISP-1000E-TV				
Displacement L/min	50Hz	1000							
	60Hz	1200							
Ultimate pressure Pa		≤ 1							
Leak tightness Pa · m ³ /s		$\leq 1.0 \times 10^{-5}$							
Max. inlet pressure		Atmospheric pressure							
Ambient operating temperature °C		10~40							
Motor	Type	3-phase squirrel cage induction motor, IE3, Totally Enclosed No Ventilated, 4-pole, Thermal class 155(F), Multiplex voltage							
	Output kW	1.4							
	Voltage V	200	220	230	380	400	415	460	
	Rated current A	50Hz	6.6	-	-	3.2	3.3	3.3	-
		60Hz	5.8	5.8	5.8	-	-	-	2.9
	Revolution min ⁻¹ {rpm}	50Hz	1450	-	-	1450	1450	1460	-
60Hz		1740	1750	1750	-	-	-	1750	
Noise level 1m dB(A) (With air-flush ON)		≤ 67 (≤ 74)							
Inlet connection		NW40							
Outlet connection		NW40							
Direction of inlet		Horizontal			Vertical				
Dimensions mm L×W×H		549×390×421			549×359×451				
Mass kg		68							
Cooling system		Air-cooled							
Others		With hour counter and air-flush							

Note 1 : Pumping speed and ultimate pressure should remain the same whether air-flush system is used or not.

Note 2 : Maximum voltage allowance is + or - 10% from motor rating.

Note 3 : Noise level is measured at ultimate pressure in an anechoic room.

Note 4 : Leak tightness is measured while the product is stopped and air flush is shut off (closed).

Note 5 : Vapor handling volume is no more than 25g/day (at 25°C 60%RH) with air-flush operation.

Air-flush flow rate is 10L/min.

Note 6 : This product is wired for 200V at the factory.

Note 7 : This product is not equipped with motor protection device.

Install branch circuit protection device for safety. Consult to qualified electrician for details.

Note 8 : This product is designed for indoor use. Install the product away from moistures or excessive humidity.

Note 9 : All data shown in this literature were measured based on our test standard and specific conditions.

Actual measurements are subject to change of conditions of use.

Note 10 : ANEST IWATA reserves the right to change descriptions or specifications in this literature without prior notice.

8.2 Dimensions

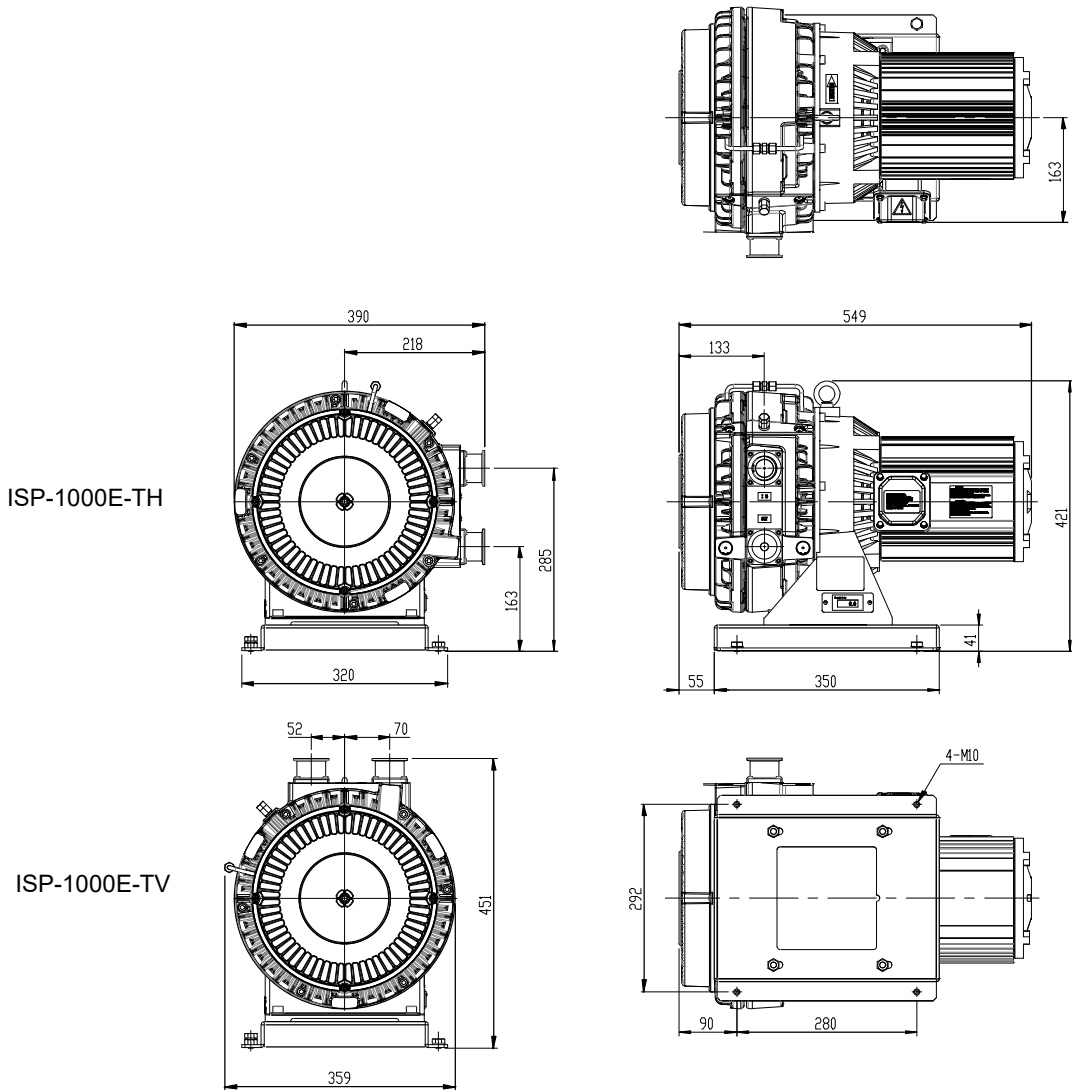

8.3 Performance data

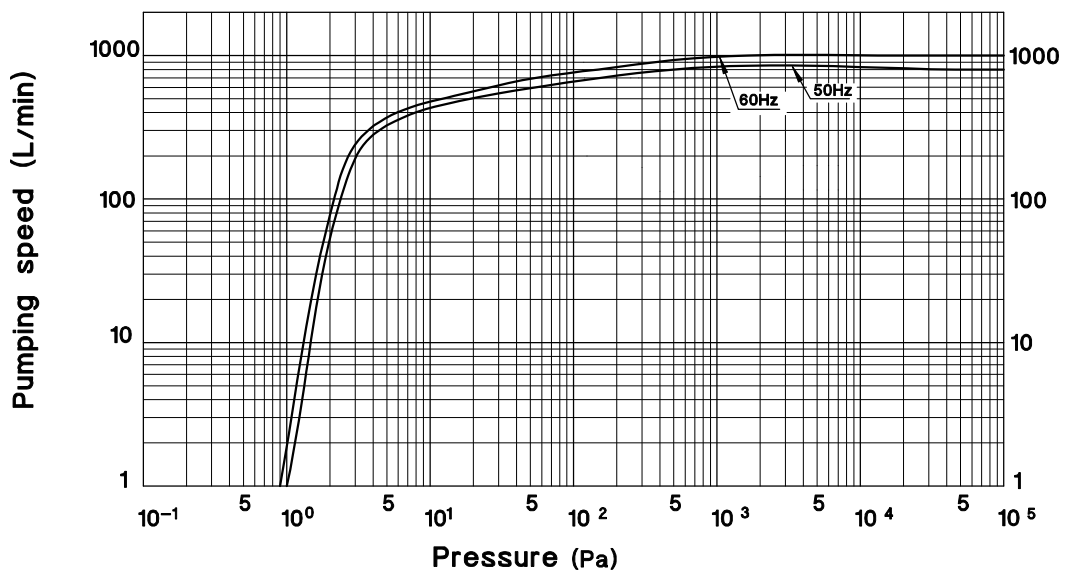

Memo

Manufacturer

 **ANEST IWATA Corporation**

3176, Shinyoshida-cho, Kohoku-Ku,
Yokohama 223-8501, Japan
Tel +81 (0) 800-100-1926
Fax +81 (0) 45-591-1539
<https://www.anest-iwata.co.jp/>

European agent

 **ANEST IWATA Europe GmbH**

Am Stahlbügel 2,
74206 Bad Wimpfen, Germany
Tel +49-7063-93-3670
<https://www.anest-iwata-air.com>