

Back view

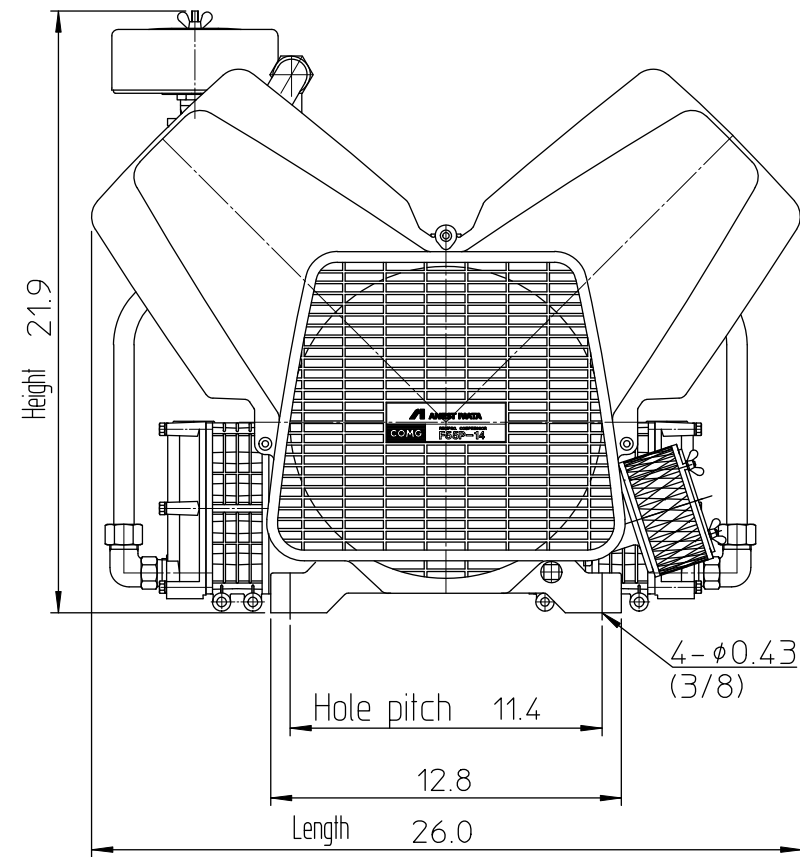

Front view

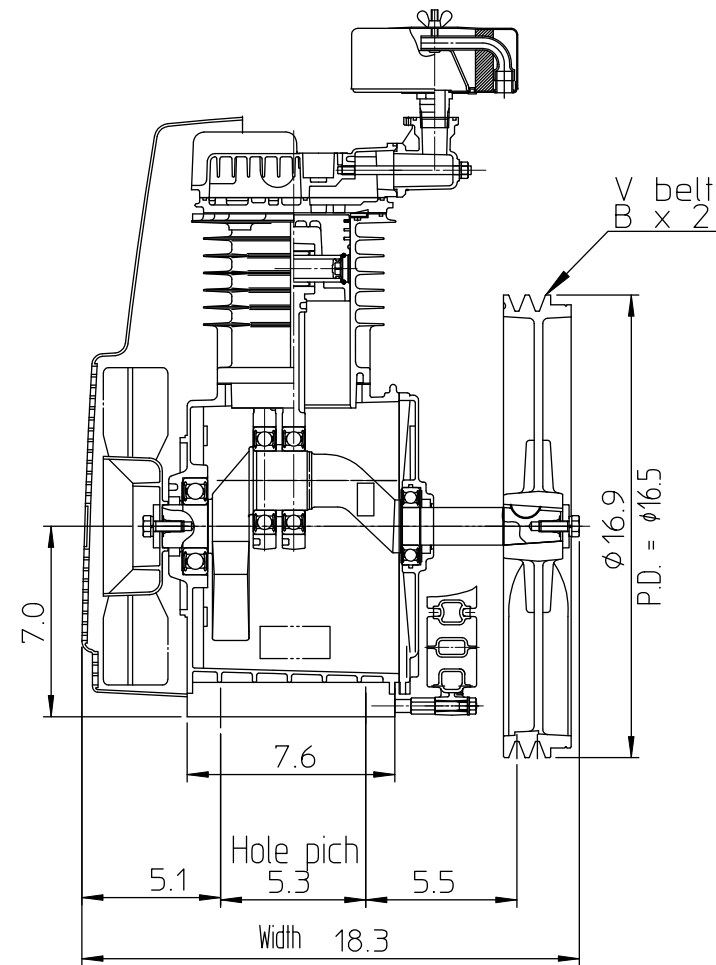

Perspective side view

Model		F55P-14-US
Pump number		F55P-14-S80
Stage number		2
Compressor power	HP	7.5
Maximum allowable pressure	psi	200
Free air delivery @ 200 psi	cfm	19.1
Weight	lb	97.0
Approx. net dimensions Length x Width x Height		inch 26.0 x 18.3 x 22.0

UNIT	inch	SCALE	1 : 7	CAD-C
MODEL	F55P-14-US			
NAME	Oil less piston Compressor			
CODE No.	F55P-14-US-301			
APP	ENG	CHE	DRA	
032514	032514	032514	032514	
A.Shirai	T.Tomita	T.Tomita	T.Tomita	
DATE	03 / 25 / 2014			
ANEST IWATA Air Engineering, Ltd.				