

Back view

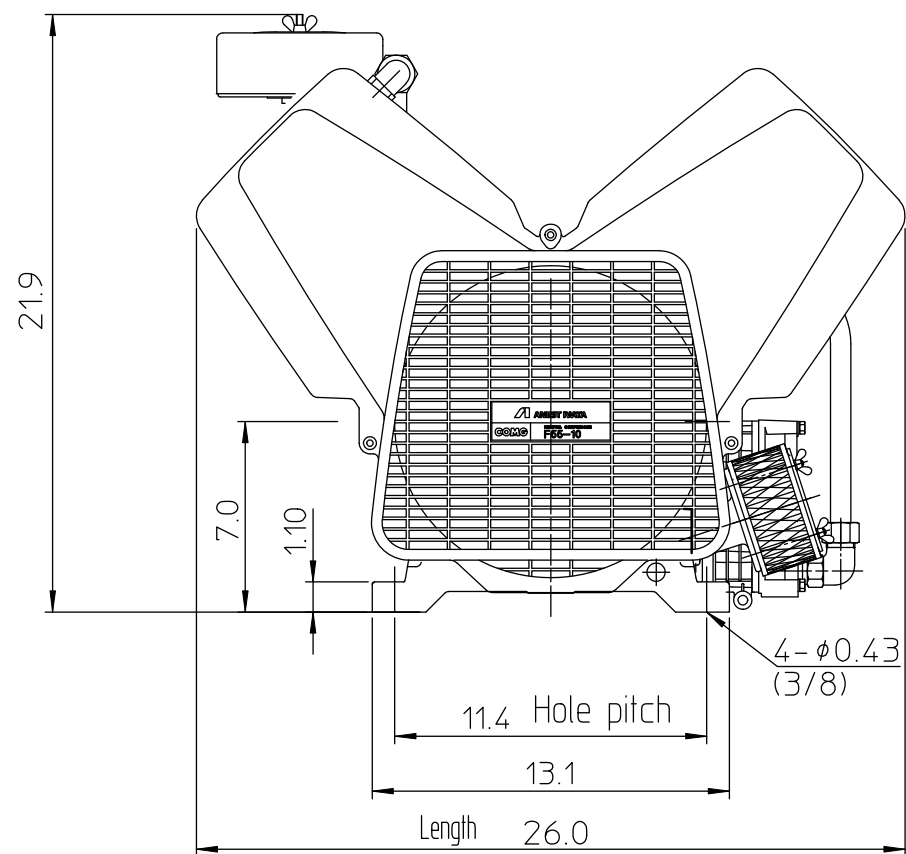

Front view

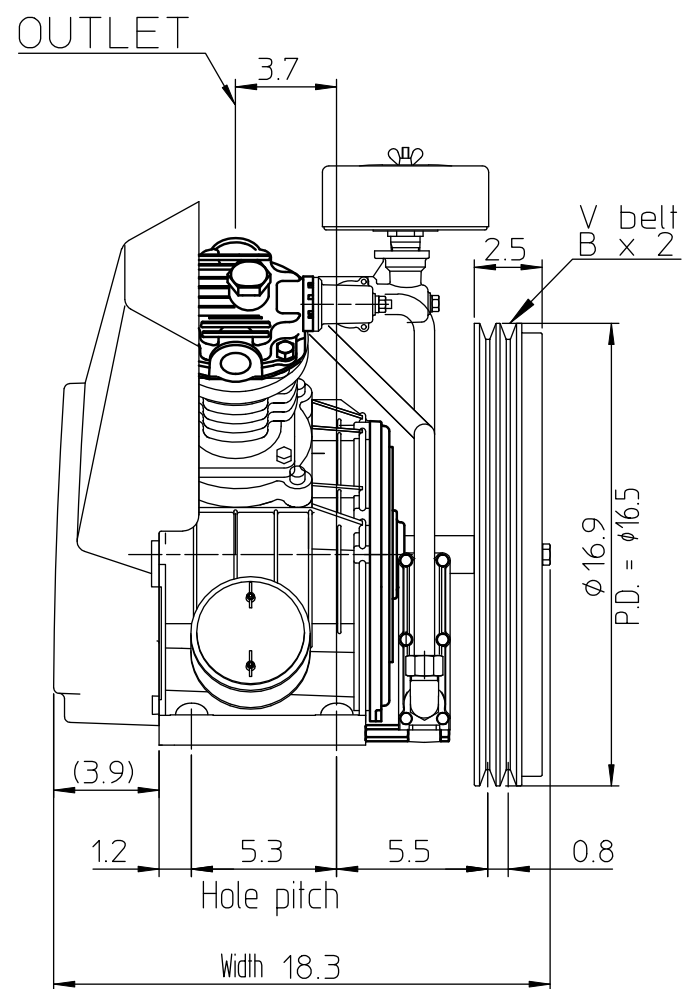

Side view

Model		F55P-10-US
Pump number		F55P-10-S80
Stage number		2
Compressor power	HP	7.5
Maximum allowable pressure	psi	145
Free air delivery @ 145 psi	cfm	20.5
Weight	lb	97.0
Approx. net dimensions Length x Width x Height	inch	26.0 x 18.3 x 21.9

UNIT	inch	SCALE	1 : 7	CAD-C
MODEL	F55P-10-US			
NAME	Oil less piston Compressor			
CODE No.	F55P-10-US-301			
APP	ENG	CHE	DRA	
032514	032514	032514	032514	
A.Shirai	T.Tomita	T.Tomita	T.Tomita	
DATE	03 / 25 / 2014			
ANEST IWATA Air Engineering, Ltd.				