

Model		F15P-10-US	
Pump number		F15P-10-S80	
Stage number		1	
Compressor power	HP	1	2
Maximum allowable pressure	psi	145	
Free air delivery @ 120 psi	cfm	3.2	5.7
Weight	lb	23.2	
Approx. net dimensions Length x Width x Height	inch	11.2 x 11.4 x 16.1	

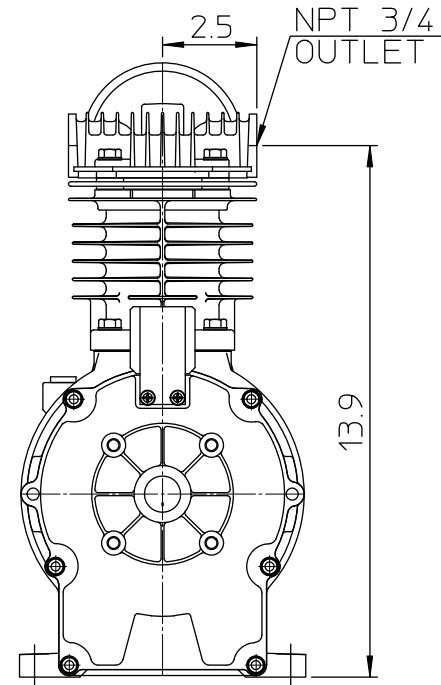

Back view

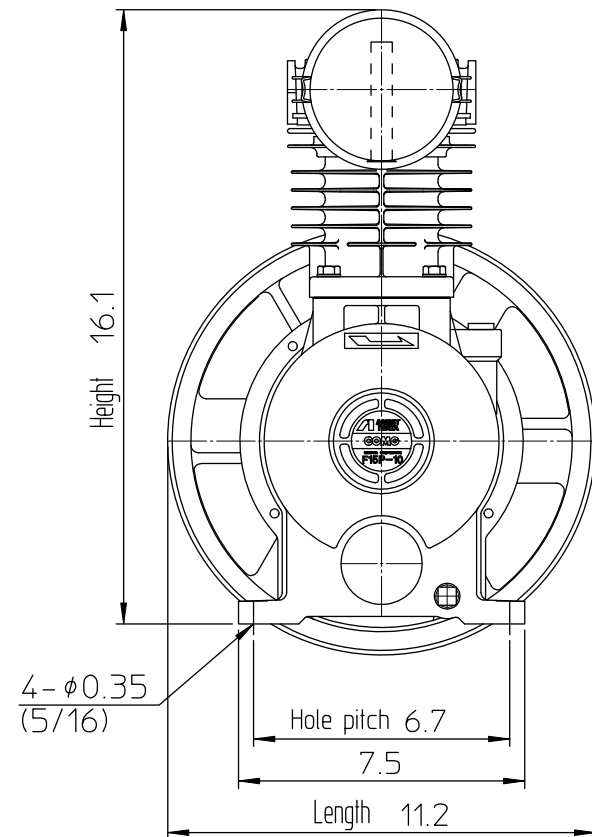

Front view

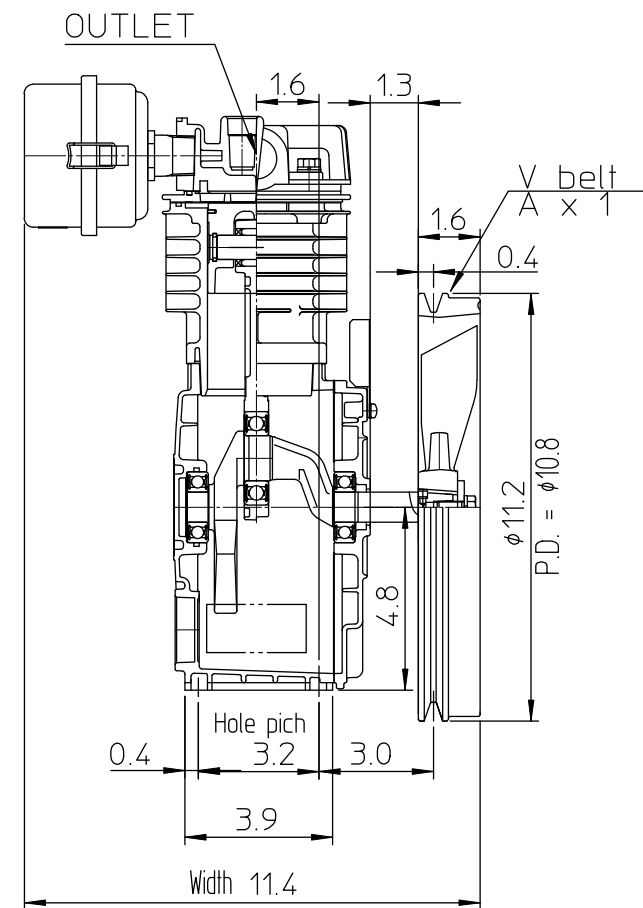

Perspective side view

UNIT	inch	SCALE	1 : 5	CAD-C
MODEL	F15P-10-US			
NAME	Oil less piston Compressor			
CODE No.	F15P-10-US-301			
APP	ENG	CHE	DRA	
032414 Atsuo	032414 Taka	032414 Taka	032414 Taka	
DATE	03 / 24 / 2014			
ANEST IWATA Air Engineering, Ltd.				