

CA72153029

# Instruction Manual (Original Instructions)

## Oil-free Scroll Vacuum Pump

# DVSL-100C-B

This instruction manual includes very important warnings, cautions and operating procedure in order to operate this pump safely and efficiently.  
Be sure to read this instruction manual thoroughly and fully understand before operation.  
After reading it, store it in a convenient place for immediate and future reading.

※Before use, be sure to fill in the blank spaces below for future repair and after-service.

Serial No.
Who sold it to you
Purchase date
When you began operation

## Declaration of Conformity

Identification of the product : Scroll Vacuum Pump

Name and address of  
the manufacturer :

ANEST IWATA Corporation  
3176, Shinyoshida-cho, Kohoku-ku,  
Yokohama 223-8501,  
Japan

Name and address of  
the authorised representative :

ANEST IWATA EUROPE GmbH  
Am Stahlbügel 2,  
74206 Bad Wimpfen,  
Germany

This declaration of conformity is issued under the sole responsibility of the manufacturer.

Object of the declaration :

Series DVSL-100C  
Models Designation DVSL-100Ca-bc

**a = S7 or blank , b = HC or blank , c = B or blank**

Ratings 1-phase, 50Hz, AC100/200/230V  
60Hz, AC100/115/200/230V

The object of the declaration described above is in conformity with the relevant  
EU harmonisation legislation :

2006 / 42 / EC Machinery Directive  
2011/65/EU & (EU)2015/863 Restriction of the use of certain Hazardous Substances  
in Electrical and electronic equipment

References to the relevant harmonised standards used or references to the specifications  
in relation to which conformity is declared :

EN 1012-2:1996+A1:2009 Compressors and Vacuum Pumps-Safety Requirements,  
Part 2: Vacuum Pumps  
EN 50581:2012 Technical documentation for the assessment of electrical  
and electronic products with respect to the restriction of  
hazardous substances

Name and address of the notified body :

TÜV Rheinland LGA Products GmbH - Tillystraße 2 - 90431 Nürnberg, Germany

Technical Documentation From File No. AM 50408294

Signed for and on behalf of the above named manufacturer :

Place and date of issue : Yokohama, Japan 1-Apr-2020  
Name, function : Hitoshi Iwata  
General Manager, Vacuum Equipment Department

Signature :

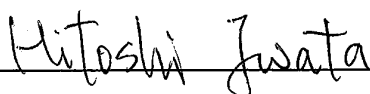
  
\_\_\_\_\_

## Important information

Be sure to read this instruction manual to understand how to operate equipment correctly. Only operators, who fully understand warnings, cautions and instructions, are to operate the equipment. Improper operation (mishandling) can cause serious bodily injury, death, fire or explosion.





Store this manual in a convenient place for immediate and future reference.



### ◆ Regarding safety

- The safety instructions given in this manual are the minimum operating requirements. Follow all national or municipal laws and regulations pertaining to fire, electricity, and other safety regulations, as well as corporate regulations.
- Pay special attention to items which are shown by the below marks and symbols.
- Symbols and marks have the following meanings.

### Examples of marks

	<b>WARNING</b>	Indicates a potentially hazardous situation which, if not avoided, may result in serious injury or loss of life.
	<b>CAUTION</b>	Indicates a potentially hazardous situation which, if not avoided, may result in minor or moderate injury or property damage.

### Examples of symbols

	Indicates [Beware]. We will explain briefly in or near the symbol. (The example on the left is [Beware of electric shock]).
	Indicates [Prohibited action]. We will explain briefly in or near the symbol. (The example on the left is [Do not touch]).
	Indicates [Required action]. We will explain briefly in or near the symbol. (The example on the left is [Be sure to ground]).

\* We shall not be responsible for any injury or damage caused by disregard of warnings, cautions or instructions.

### Supplementary notes



<b>Important</b>	Indicates notes which we ask you to observe. They are helpful to achieve full performance and functionality of the equipment.
------------------	---

# For safe operation

Below is very important information about how to safely operate the equipment. Before operation, be sure to read and fully understand the contents.













## WARNING

 <b>Be careful about lifting</b>	<b>Danger of cargo collapse</b> Be careful to install vacuum pump using motor handle (DVSL-100C-B mass 17kgs) while paying attention to stability of suspended load. If not, it can cause damage, failure or bodily injury from falling cargo due to hoisting failure, or by being caught between suspended cargo and other material.	 <b>Avoid moisture</b>	<b>Danger of electric shock</b> Install in an area which is not exposed to moisture such as rain or steam. If moisture comes into and tact with the electric source connection, it can cause fire or bodily injury due to short-circuit or electric shock.
 <b>Install at a safe site</b>	<b>Danger of explosion, fire and accident</b> Install in an area free from explosive, flammable or corrosive substances. If not, it can cause explosion, fire or accident.	 <b>Ask qualified electrician</b>	<b>Danger of short-circuit and electric shock</b> Ask a qualified electrician to perform electric wiring. If not, short-circuit or electric shock can cause fire or bodily injury.
 <b>Turn off electric source</b>	<b>Danger of electric shock and entanglement</b> Be sure to turn off electric source on building site before wiring. If not, it can cause electric shock or bodily injury due to turning objects.	 <b>Install overcurrent protective device</b>	<b>Danger of accident, fire and failure</b> Be sure to install protective device to protect circuitry. We recommend overcurrent protective device (rated 15A) to protect branch circuit. If equipment is not stopped in an emergency, it can cause accident, fire or failure.
 <b>Install emergency stop switch</b>	<b>Danger of accident, fire or failure</b> Be sure to install an electric source emergency stop switch (or protective device that can urgently stop). If equipment is not stopped in an emergency, it can cause accident, fire or failure.	 <b>Install short circuit protective device</b>	<b>Danger of fire and electric shock</b> Install short circuit protective device. If not, it can cause bodily injury due to fire or electric shock.
 <b>Install motor protective circuit breaker to protect motor</b>	<b>Danger of electric fire and electric shock</b> Install motor protective circuit breaker to protect motor. If not, bodily injury due to electric fire or electric shock can result. If you have any questions about the selection of protective devices, contact either the dealer who sold it to you or us.	 <b>Be careful about wiring</b>	<b>Danger of short-circuit and electric shock</b> We recommend an electric source cable of more than <u>2mm<sup>2</sup> (more than rated 10A) cross section area for electric source cable and earth cord.</u> Be careful to avoid voltage drop considering local situation. If not, it can cause a short-circuit fire and may result in bodily injury from electric shock.
 <b>Use crimp-style terminal</b>	<b>Danger of short-circuit and electric shock</b> Fit firmly proper round type crimp-style terminal to electric source cable using crimp tool and connect to motor terminal section. If not, it can cause short-circuit fire or bodily injury from electric shock due to looseness or disconnection.	 <b>Protect cable from being pulled</b>	<b>Danger of short-circuit and electric shock</b> Be sure to fit cable-gland to hole of φ22mm at motor terminal box. If not, it can cause short-circuit fire or bodily injury from electric shock.

# For safe operation















## WARNING

 <p><b>Protect cable from being pulled</b></p>	<p><b>Danger of short-circuit and electric shock</b></p> <p>The power-supply conductor shall be free from strain including twisting by using cord anchorage, which is specified by the local electrical wiring regulation. If not, it can cause short-circuit fire or bodily injury from electric shock.</p>	 <p><b>Be sure to ground</b></p>	<p><b>Danger of electric shock</b></p> <p>Connect earth cord to earth terminal in motor terminal box. If not, it can cause bodily injury from electric shock.</p>
 <p><b>With a thermal protector</b></p>	<p><b>Danger of restart</b></p> <p>Be sure to switch off electric source before maintenance or inspection. Single-phase motor has a thermal protector. Vacuum pump restarts become cool without warning after vacuum pump.</p>	 <p><b>Never evacuate hazardous gas</b></p>	<p><b>Danger of explosion and ignition</b></p> <p>Do not evacuate gas which is hazardous to humans or explosive, flammable, or corrosive. Do not evacuate with substances containing chemicals, solvents, and powders. If done, it can cause failure or bodily injury by gas, explosion or ignition. It is not guaranteed fluorine rubber can be used for all solvents.</p>
 <p><b>Avoid foreign matter</b></p>	<p><b>Danger of entanglement and foreign matter dispersal</b></p> <p>Never put finger or foreign matter into air holes of bracket. If done, it can cause bodily injury from entanglement with turning section, or foreign matter dispersal.</p>	 <p><b>Never alter</b></p>	<p><b>Danger of electric shock and entanglement</b></p> <p>Do not remove or alter safeguards or insulation parts. If done, it can cause bodily injury from electric shock or turning section and it can cause deteriorated performance and operating lifetime, and invalidate guarantee.</p>
 <p><b>Change after vacuum pump is stopped</b></p>	<p><b>Danger of failure and bodily injury</b></p> <p>Change air-flush port only after vacuum pump is stopped. If you change it during vacuum pump operation, it can cause vacuum pump failure and bodily injury.</p>	 <p><b>Conduct periodical maintenance and inspection</b></p>	<p><b>Danger of failure and bodily injury</b></p> <p>Conduct periodical maintenance and inspection. If not, it can cause insufficient performance, failure of vacuum pump, and bodily injury.</p>
 <p><b>Be careful about high temperature</b></p>	<p><b>Danger of burns</b></p> <p>Conduct maintenance and inspection only after vacuum pump becomes cool enough. Maintenance and inspection soon after vacuum pump stops can cause burn injury.</p>	 <p><b>Turn off electric source</b></p>	<p><b>Danger of electric shock</b></p> <p>Be sure to conduct maintenance and inspection after you turn off electric source. If not, it can cause bodily injury from electric shock or turning object.</p>
 <p><b>Ask specialist to perform repairs</b></p>	<p><b>Danger of accident, failure and shorter operating lifetime</b></p> <p>Ask specialist to perform repairs. Defective repairs can cause accident, failure or shorter operating lifetime.</p>	-	

# For safe operation



## CAUTION

 <b>Use at designated temperature</b>	<b>Danger of overheating</b> Operate at ambient temperature of 5°C ~40°C. Operating at a temperature range other than that designated can cause accident, failure or bodily injury such as burns due to overheating.	 <b>Pay attention to ventilation</b>	<b>Danger of overheating</b> Install in a well-ventilated area. Poor ventilation can disrupt cooling and cause accident, failure or bodily injury such as burns since this vacuum pump is an air-cooled type.
 <b>Avoid dust</b>	<b>Danger of dust</b> Be sure site is free from dust. Sucking in of dust can cause failure.	 <b>Install on a solid, level floor</b>	<b>Danger of unbalance</b> Be sure to fix vacuum pump on solid and level floor (less than 5° inclination). Uneven fix can cause failure and movement of vacuum pump. Fix pump base with 4 bolts using hole of φ9mm at bracket.
 <b>Avoid direct sunlight</b>	<b>Danger of overheating</b> Install where equipment is not exposed to direct sunlight. Vacuum pump exposed to direct sunlight can overheat, resulting in failure.	 <b>Check voltage</b>	<b>Motor burnout</b> Before doing any wiring, check electric source and voltage. This pump is a multi voltage type of AC100V/AC200V. <u>Voltage can be changed at terminal block. This pump is wired to 100V when shipping from factory.</u> Check your electric source, voltage, and cord correctly to terminal block. Improper wiring and incorrect voltage can cause motor burnout.
 <b>Inspect cause of problem</b>	<b>Danger of problem recurrence and failure</b> If protective device or thermal protector activates, be sure to turn off electric source and inspect causes to solve the problem. Do not operate until problem is solved. Operation while problem is left unsolved can cause problem recurrence and failure.	 <b>Remove cap</b>	<b>Danger of cap to fly</b> Remove cap from inlet and outlet. Operation with cap being fitted can cause cap to fly by intake or exhaust impetus, resulting in accident, failure, or bodily injury from contact with flying objects.
 <b>Prevent human body from contacting</b>	<b>Danger of human body parts contacting vacuum</b> At starting up of the vacuum pump and during operation, be careful not to enter human body into the inlet. You can cause injury to people and damage to equipment.	 <b>Prevent foreign matter from entering</b>	<b>Danger of foreign matter entering inlet</b> When checking turning direction, be careful not to enter foreign matter into an inlet. Foreign matter entering inlet can cause failure.
 <b>Check fan</b>	<b>Danger of overheating</b> Check that cooling fan is turning and cooling air is flowing. If not, it can cause accident, failure or bodily injury such as burns due to overheating.	 <b>Pay attention to exhaust resistance</b>	<b>Danger of exhaust disruption</b> When connecting exhaust piping to vacuum pump and when combining piping with another vacuum pump, pay attention to piping size and length so that it does not cause exhaust resistance. Exhaust resistance can disrupt air flow, resulting in failure and over-current.

# For safe operation



## CAUTION

 <p><b>Prevent foreign matter from entering</b></p>	<p><b>Danger of foreign matter entering inlet</b></p> <p>If you use the seal material or the adhesive, etc. to prevent Leak of the joint when piping with internal screw of inlet, be careful not to enter the seal material or the adhesive into an inlet. The seal material or the adhesive entering inlet can cause failure.</p>	 <p><b>Start or stop after closing isolation valve</b></p>	<p><b>Danger of vacuum break and pollution</b></p> <p>Be sure to close isolation valve between vacuum pump and vacuum system (chamber) during start-up and stop. Start-up or stop with isolation valve in the open position can draw back gas and debris attached to inside of pump to vacuum chamber due to pressure differential, resulting in vacuum break and pollution on vacuum chamber side.</p>
 <p><b>Beware temperature of intake gas</b></p>	<p><b>Danger of exceeding permissible temperature of intake gas</b></p> <p>If intake gas temperature is over 50°C, be sure to install a chiller or trap between vacuum pump and vacuum chamber so that gas intake temperature of vacuum pump keeps below 50°C. If not, vacuum pump temperature can increase, resulting in failure.</p>	 <p><b>Operate while opening air-flush port</b></p>	<p><b>Danger of remaining moisture</b></p> <p>When evacuating moisture, be sure to open air-flush port (air-flush operation). If you evacuate vapor while air-flush port is closed, condensed water will remain inside vacuum pump and cause failure.</p>
 <p><b>Caution after exhausting vapor</b></p>	<p><b>Danger of insufficient vapor exhaust</b></p> <p>After evacuating vapor, do air-flush operation for at least one hour. If you close air-flush port or stop vacuum pump soon after evacuating vapor, condensed water will remain inside vacuum pump which will cause failure.</p>	 <p><b>Beware of intake gas volume</b></p>	<p><b>Danger of exceeding permissible intake gas volume</b></p> <p>When sending N<sub>2</sub> gas or dry air into air-flush port, pressure should be the same as atmospheric pressure and flow rate should be less than 5L/min. If not, it can increase pressure inside vacuum pump, resulting in failure.</p>
 <p><b>Caution for frequent start/stop and short interval</b></p>	<p><b>Risk of motor malfunction</b></p> <p>Refrain from frequent start/stop operation. It induces malfunction of motor such as burn out. Please consult your dealer or factory representative for details. Appropriate operating mode with adequate interval and frequency of start/stop is varies owing to operating condition.</p>		

# Where to attach warning stickers

## Where to attach warning stickers

Always keep warning stickers clean and legible. If they become dirty or detached, replace them with new ones. If you need replacement stickers, contact the dealer who sold the vacuum pump to you.

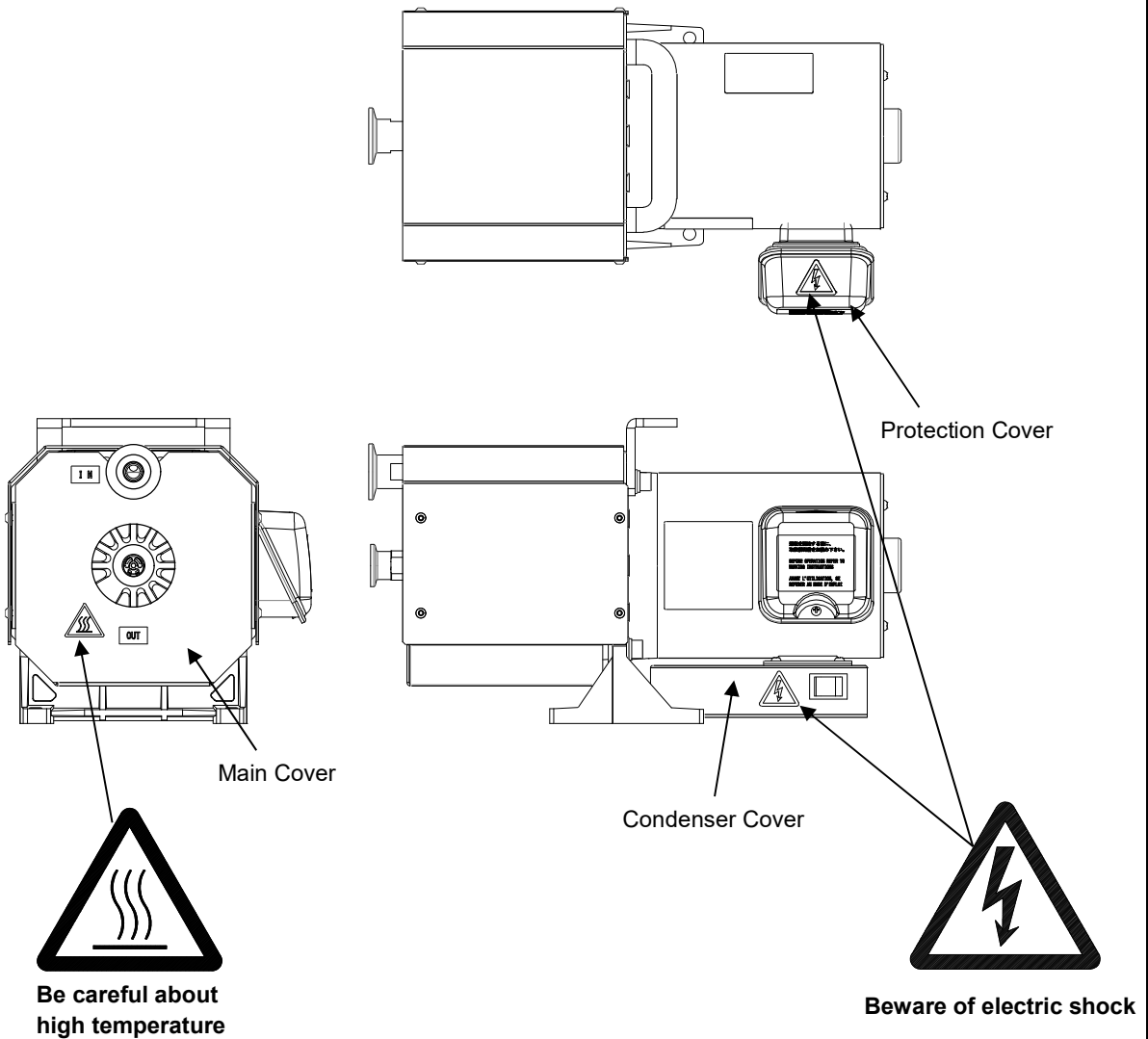



# Contents

Important information .....	1
For safe operation .....	2
Contents .....	7
1. Before use .....	8
1.1 Check the product .....	8
2. Name and structure of each section .....	10
3. Installation.....	11
3.1 Wiring.....	12
3.2 Test operation .....	16
3.3 Connection to vacuum system (chamber).....	17
4. Operation.....	18
4.1 Standard operation.....	20
4.1.1 Start-up .....	20
4.1.2 Shut-down.....	20
4.2 Air-flush operation.....	21
4.2.1 Preparation .....	21
4.2.2 Start-up and shut-down.....	22
4.2.3 When returning to standard operation .....	22
5. Maintenance and inspection .....	23
5.1 Daily maintenance and inspection .....	23
5.2 Maintenance .....	24
6. Problems and remedies.....	25
7. Disposal.....	25
8. Specifications .....	26
8.1 Specifications .....	26
8.2 Dimensions .....	26
8.3 Performance data .....	27

# 1. Before use

## 1.1 Check the product

- Check that the package is right-side-up before opening.
- Check that the model of the product is the same as the one you ordered.

How to read model name

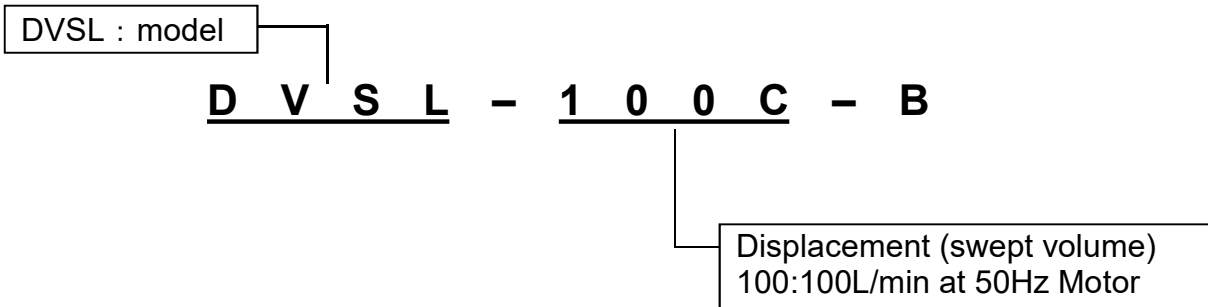

- **Check that there is no damage.**  
If there is any damage, contact either the dealer who sold it to you or us.
- **Check the following accessories.**  
Instruction manual (this one)  
Air-muffler for air-flushing (which is attached to the grip)

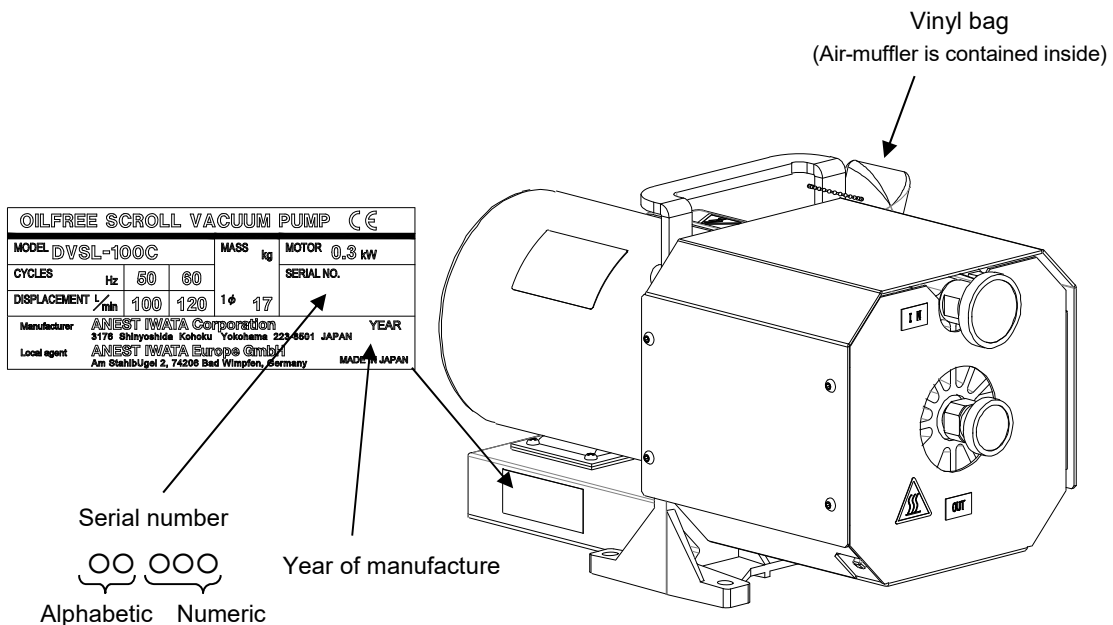

※Please prepare electric source cables, crimp-style terminal, electric source protective devices, piping to inlet, and piping from outlet on customer side.

## Open package



## WARNING

### Danger of cargo collapse

Hold the motor handle of the product (DVSL-100C mass 17kgs) firmly, when installing vacuum pump.

If not, it can cause damage, failure or bodily injury from falling vacuum pump, or by being caught between vacuum pump and other material.



Be careful about lifting

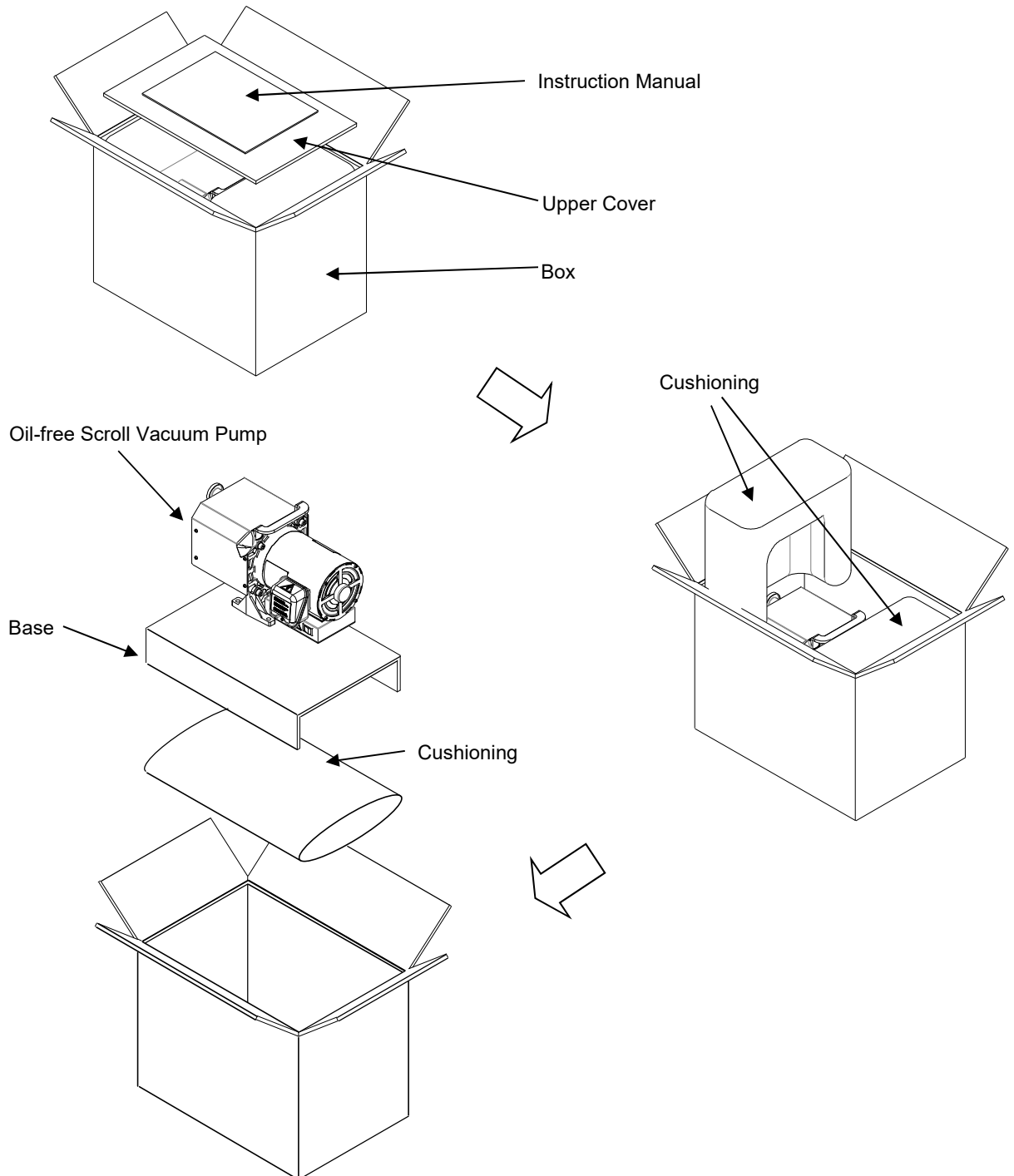



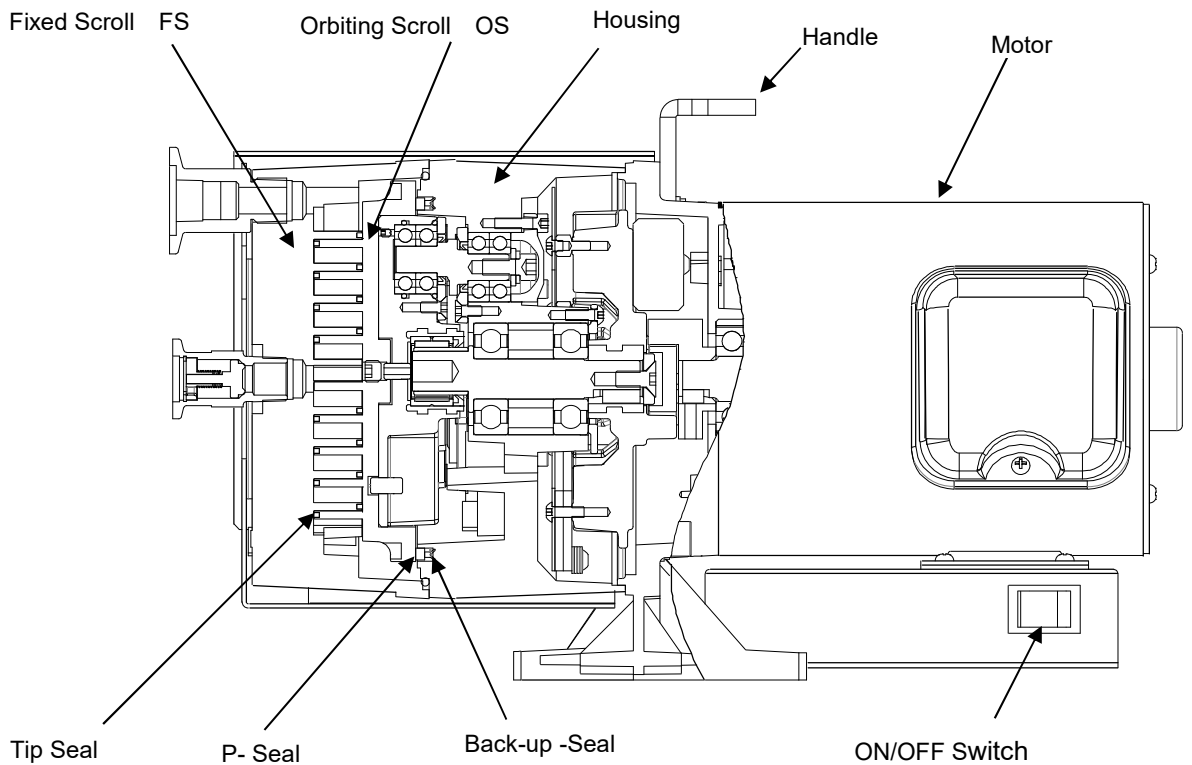
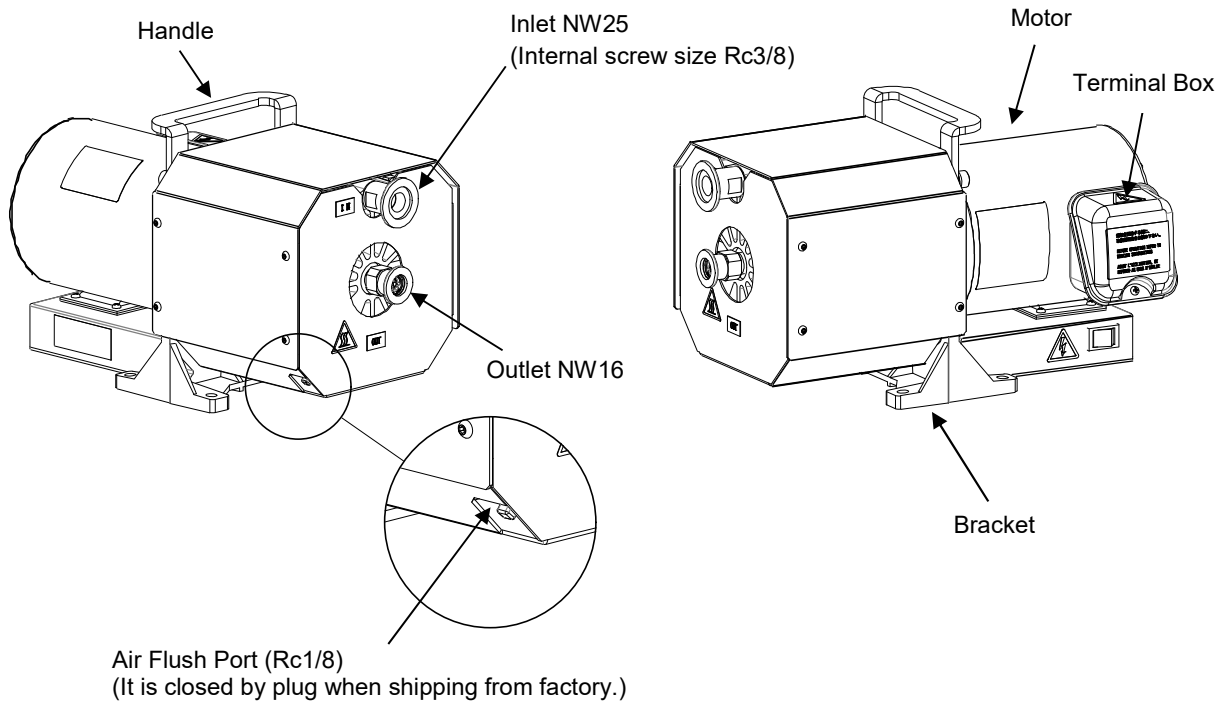





## 2. Name and structure of each section



**Structure of vacuum pump**













### 3. Installation

 <b>WARNING</b>			
<b>Danger of electric shock</b> <b>Install in an area which is not exposed to moisture such as rain or steam.</b> If moisture comes into and tact with the electric source connection, it can cause fire or bodily injury due to short-circuit or electric shock.	 <b>Avoid moisture</b>		
<b>Danger of explosion, fire and accident</b> <b>Install in an area free from explosive, flammable or corrosive substances.</b> If not, it can cause explosion, fire or accident.	 <b>Install at a safe site</b>		
 <b>CAUTION</b>			
<b>Danger of overheating</b> <b>Operate at ambient temperature of 5°C~40°C.</b> Operating at a temperature range other than that designated can cause accident, failure or bodily injury such as burns due to overheating.	 <b>Use at designated temperature</b>		
<b>Danger of overheating</b> <b>Install in a well-ventilated area (refer to below chart).</b> Poor ventilation can disrupt cooling and cause accident, failure or bodily injury such as burns since this vacuum pump is an air-cooled type. Do not block inlet and outlet of cooling air with obstruction.	 <b>Pay attention to ventilation</b>		
<table border="1" style="margin: auto;"> <tr> <td style="padding: 5px;"><b>Necessary ventilated air volume</b></td> </tr> <tr> <td style="padding: 5px;"><b>Over 2m<sup>3</sup>/min</b></td> </tr> </table>	<b>Necessary ventilated air volume</b>	<b>Over 2m<sup>3</sup>/min</b>	
<b>Necessary ventilated air volume</b>			
<b>Over 2m<sup>3</sup>/min</b>			
<b>Danger of dust</b> <b>Be sure site is free from dust.</b> Sucking in of dust can cause failure.	 <b>Avoid dust</b>		
<b>Danger of movement</b> <b>Be sure to fix vacuum pump on solid and level floor (less than 5° inclination).</b> Uneven fix can cause failure and movement of vacuum pump. Fix pump base with 4 bolts using hole of φ9mm at bracket.	 <b>Install on a solid, level floor</b>		
<b>Danger of overheating</b> <b>Install where equipment is not exposed to direct sunlight.</b> Vacuum pump exposed to direct sunlight can overheat, resulting in failure.	 <b>Avoid direct sunlight</b>		



### Important

When building vacuum pump into vacuum system, pay attention to space for maintenance, ambient temperature and piping. Be sure to fix vacuum pump on solid and level floor.  
 If you have any questions, contact the dealer who sold it to you or us.

### 3.1 Wiring

 <b>WARNING</b>	
<p><b>Danger of short-circuit and electric shock</b></p> <p><b>Ask a qualified electrician to perform electrical wiring.</b> If not, short-circuit or electric shock can cause fire or bodily injury.</p>	 <b>Ask qualified electrician</b>
<p><b>Danger of electric shock and entanglement</b></p> <p><b>Be sure to turn off electric source on building site before wiring.</b> If not, it can cause electric shock or bodily injury due to turning objects.</p>	 <b>Turn off electric source</b>
<p><b>Danger of accident, fire and failure</b></p> <p><b>Be sure to install protective device to protect circuitry. We recommend overcurrent protective device (rated 15A) to protect branch circuit.</b> If equipment is not stopped in an emergency, it can cause accident, fire or failure.</p>	 <b>Install overcurrent protective device</b>
<p><b>Danger of accident, fire or failure</b></p> <p><b>Be sure to install an electric source emergency stop switch (or protective device that can urgently stop).</b> If equipment is not stopped in an emergency, it can cause accident, fire or failure.</p>	 <b>Install emergency stop switch</b>
<p><b>Danger of fire and electric shock</b></p> <p><b>Install short circuit protective device.</b> If not, it can cause bodily injury due to fire or electric shock.</p>	 <b>Install short circuit protective device</b>
<p><b>Danger of electric fire and electric shock (refer to chart 1 on page 14)</b></p> <p><b>Install motor protective circuit breaker to protect motor.</b> If not, bodily injury due to electric fire or electric shock can result. If you have any questions about the selection of protective devices, contact either the dealer who sold it to you or us.</p>	 <b>Install motor protective circuit breaker to protect motor</b>
<p><b>Danger of short-circuit and electric shock</b></p> <p><b>We recommend an electric source cable of more than <u>2mm<sup>2</sup> (more than rated 10A) cross section area for electric source cable and earth cord.</u></b> <b>Be careful to avoid voltage drop considering local situation.</b> If not, it can cause a short-circuit fire and may result in bodily injury from electric shock.</p>	 <b>Be careful about wiring</b>
<p><b>Danger of short-circuit and electric shock</b></p> <p><b>Fit firmly proper round type crimp-style terminal to electric source cable using crimp tool and connect to motor terminal section.</b> If not, it can cause short-circuit fire or bodily injury from electric shock due to looseness or disconnection.</p>	 <b>Use crimp-style terminal</b>
<p><b>Danger of short-circuit and electric shock</b></p> <p><b>Be sure to fit cable-gland to hole of <math>\phi</math> 22mm at motor terminal box.</b> If not, it can cause short-circuit fire or bodily injury from electric shock.</p>	 <b>Protect cable from being pulled</b>
<p><b>Danger of short-circuit and electric shock</b></p> <p><b>The power-supply conductor shall be free from strain including twisting by using cord anchorage, which is specified by the local electrical wiring regulation.</b> If not, it can cause short-circuit fire or bodily injury from electric shock.</p>	 <b>Protect cable from being pulled</b>
<p><b>Danger of electric shock</b></p> <p><b>Connect earth cord to earth terminal in motor terminal box.</b> If not, it can cause bodily injury from electric shock.</p>	 <b>Be sure to ground</b>

<p><b>Danger of restart</b>  <b>Be sure to switch off electric source before maintenance or inspection.</b>  <b>Single-phase motor has a thermal protector.</b>          Vacuum pump restarts become cool without warning after vacuum pump.</p>	 <b>With a thermal protector</b>
<p><b>CSA Requirement</b>          Thermally protected automatic reset. TYPE TP212. Motor restart without warning after protector trip.          Min. circuit ampacity of conductor is 10A          Max. branch circuit breaker is 15A</p> <p><b>When you used this pump in Europe.</b>          This vacuum pump must be equipped with a main disconnect device in accordance with requirements of EN60204-1, clause 5.3.2. It is recommended to use a circuit breaker as main breaker which is suitable for isolation according to EN60947-2 and is equipped with an operating handle which is lockable in OFF position and complies with the other requirements of EN60204-1, clause 5.3</p>	

 <b>CAUTION</b>	
<p><b>Motor burnout</b>  <b>Before doing any wiring, check electric source and voltage.</b>  <b>This pump is multi voltage type of AC100V/AC200V.</b>  <u><b>Voltage can be changed at terminal block.</b></u>  <u><b>This pump is wired to 100V when shipping from factory.</b></u>  <b>Check your electric source, voltage, and cord correctly to terminal block.</b>          Improper wiring and incorrect voltage can cause motor burnout.</p>	 <b>Check voltage</b>
<p><b>Danger of problem recurrence and failure</b>  <b>If protective device activates, be sure to turn off electric source and inspect causes to solve the problem. Do not operate until problem is solved.</b>          Operation while problem is left unsolved can cause problem recurrence and failure.</p>	 <b>Inspect cause of problem</b>

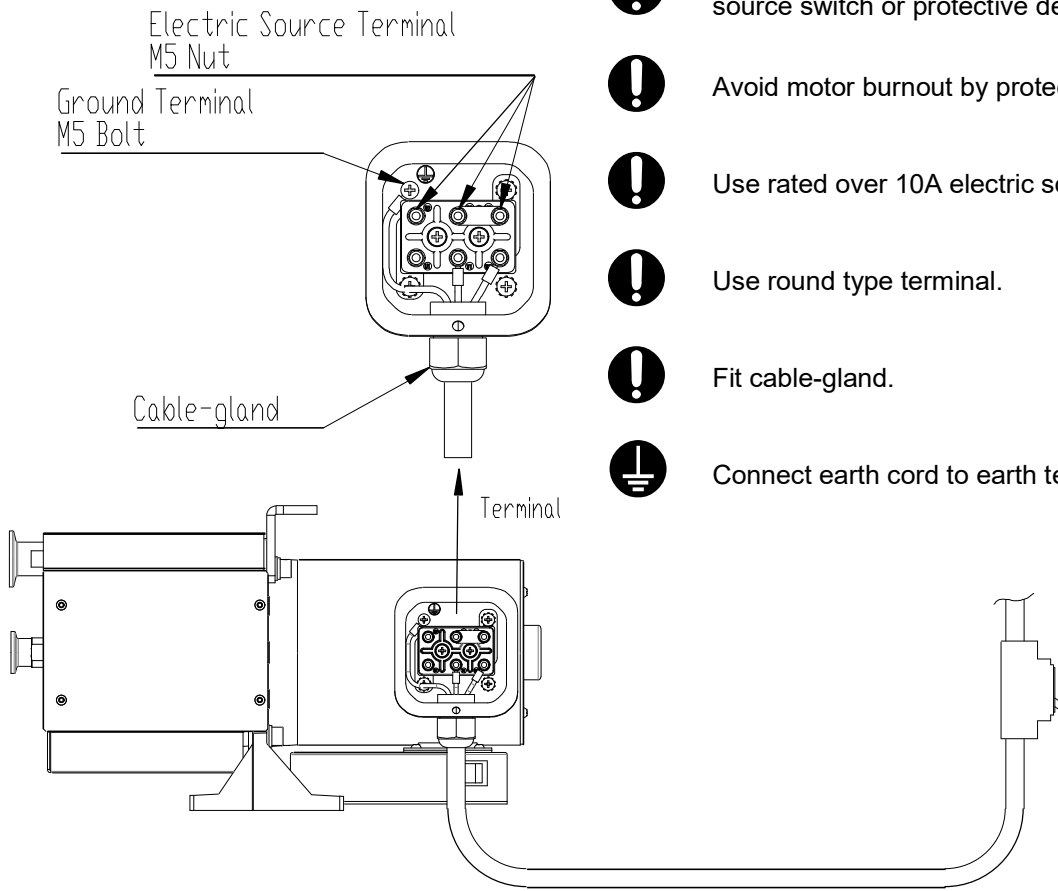

- ❗ Activate the emergency stop by electric source switch or protective device.
- ❗ Avoid motor burnout by protective device (chart 1).
- ❗ Use rated over 10A electric source cable and earth cord.
- ❗ Use round type terminal. 
- ❗ Fit cable-gland.
- ⚡ Connect earth cord to earth terminal.

Chart—1

Voltage V	Frequency Hz	Recommended breaker (or protective device) capacity A
100	50	3.3
100	60	3.6
115	60	3.5
200	50	1.6
200	60	2.0
230	50	1.8
230	60	1.8





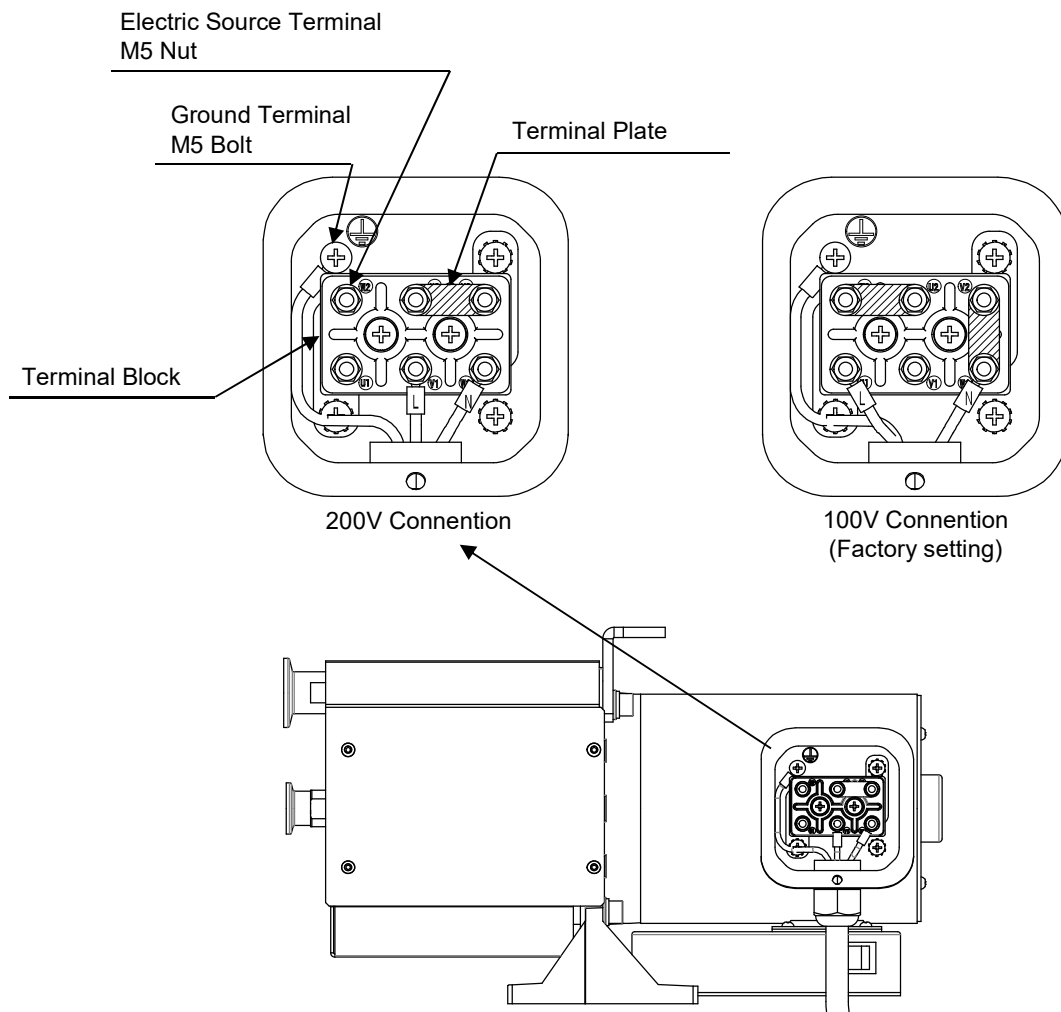

## How to wire

- ① Remove 1pcs. of M5 bolt at motor terminal box and remove protection cover.  
※Be sure to keep M5 bolts and washer, which were removed from the protection cover.
- ② Wiring diagram is shown inside protection cover.  
You can change to a 100V or 200V connection by changing terminal plate (2pcs.).  
**※It is wired to 100V when shipping from factory.**
- ③ If you want to change to a 200V connection, remove M5 nut of electric source terminal and change terminal plate as illustrated below.
- ④ Connect electric cable to terminal by using cable-gland at  $\phi 22\text{mm}$  hole of motor terminal box.
- ⑤ Insert electric source cable through cable-gland on the bottom side of terminal box.
- ⑥ Connect each phase L-N to each electric source terminal respectively in accordance with the below wiring diagram.  
Terminal screw nuts should be torqued between  $1.2\text{ N} \cdot \text{m}$  and  $1.5\text{ N} \cdot \text{m}$ .
- ⑦ The protective earth cord shall be suffice in length and put up to keep the cord the last to take the strain if the cable slips in its anchorage.



## 3.2 Test operation

 <b>CAUTION</b>	
<p><b>Danger of cap to fly</b>  <b>Remove cap from inlet and outlet.</b>            Operation with cap being fitted can cause cap to fly by intake or exhaust impetus, resulting in accident, failure, or bodily injury from contact with flying objects.</p>	 <b>Remove cap</b>
<p><b>Danger of human body parts contacting vacuum</b>  <b>At starting up of the vacuum pump and during operation, be careful not to enter human body into the inlet.</b>            You can cause injury to people and damage to equipment.</p>	 <b>Prevent human body from contacting</b>
<p><b>Danger of foreign matter entering inlet</b>  <b>When checking turning direction, be careful not to enter foreign matter into an inlet.</b>            Foreign matter entering inlet can cause failure.</p>	 <b>Prevent foreign matter from entering</b>
<p><b>Danger of overheating</b>  <b>Check that cooling fan is turning and cooling air is flowing.</b>            If not, it can cause accident, failure or bodily injury such as burns due to overheating.</p>	 <b>Check fan</b>

### Test operation

- ① Open inlet and outlet  
 Remove caps (2 places)  
 from inlet and outlet of  
 vacuum pump.

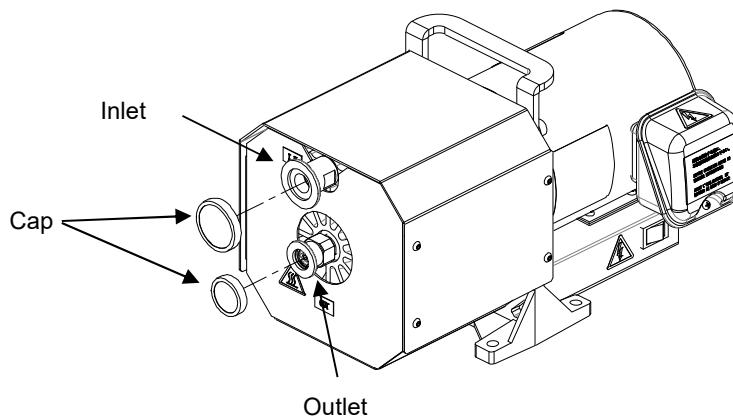

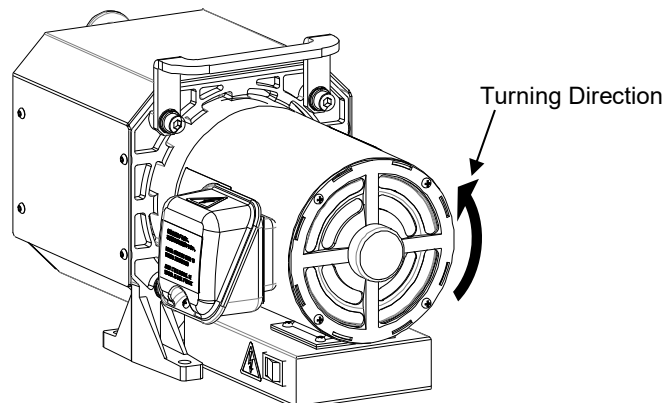

- ② Check turning direction  
 Open inlet, turn on electrical  
 source to start operating  
 vacuum pump, and Check  
 that air comes out from outlet.



If you fit pump to vacuum system and control operation of vacuum pump by remote control, **first check pump itself for turning direction** and then fit it to vacuum system.

### 3.3 Connection to vacuum system (chamber)

Inlet is NW25 (Internal screw size : Rc 3/8) and outlet is NW16.

 <b>CAUTION</b>	
<p><b>Danger of exhaust disruption</b></p> <p>When connecting exhaust piping to vacuum pump and when combining piping with another vacuum pump, pay attention to piping size and length so that it does not cause exhaust resistance.</p> <p>Exhaust resistance can disrupt air flow, resulting in failure and over-current.</p>	 <b>Pay attention to exhaust resistance</b>
<p><b>Danger of foreign matter entering inlet</b></p> <p>If you use the seal material or the adhesive, etc. to prevent Leak of the joint when piping with internal screw of inlet, be careful not to enter the seal material or the adhesive into an inlet.</p> <p>The seal material or the adhesive entering inlet can cause failure.</p>	 <b>Prevent foreign matter from entering</b>

### Important

**Use isolation valve between vacuum system and inlet.**

Isolation valve is necessary to prevent the drawback of debris attached to the inside of vacuum pump into the vacuum chamber during start-up and shut-down. (We recommend the use of leak valve also). We recommend the use of an automatic valve as the isolation valve which closes during power failure in order to prevent the drawback of debris inside pump into the vacuum chamber during power failure.

**Use an appropriate and clean connecting pipe between vacuum chamber and vacuum pump.**

Use the clean connecting pipe between vacuum chamber and vacuum pump.

We recommend the use of a flexible tube between the inlet of vacuum pump and outlet of vacuum chamber so that vibration of the vacuum pump can be isolate.

**When connecting exhaust piping to the outlet of vacuum pump, refer to the following instructions.**

Never exceed **9-meter** in length in straight line when extending exhaust pipe. The pipe size should be no smaller than **Rc3/8 (inner dia.12.5)**

When longer extension of exhaust piping is required, adopt larger exhaust pipe size.

**Make sure that exhaust piping is not blocked during pump operation.**

Make sure that pressure at outlet does not exceed atmospheric pressure at any conditions.

**In order to keep condensation away from feeding into the exhaust port, take proper measure.**



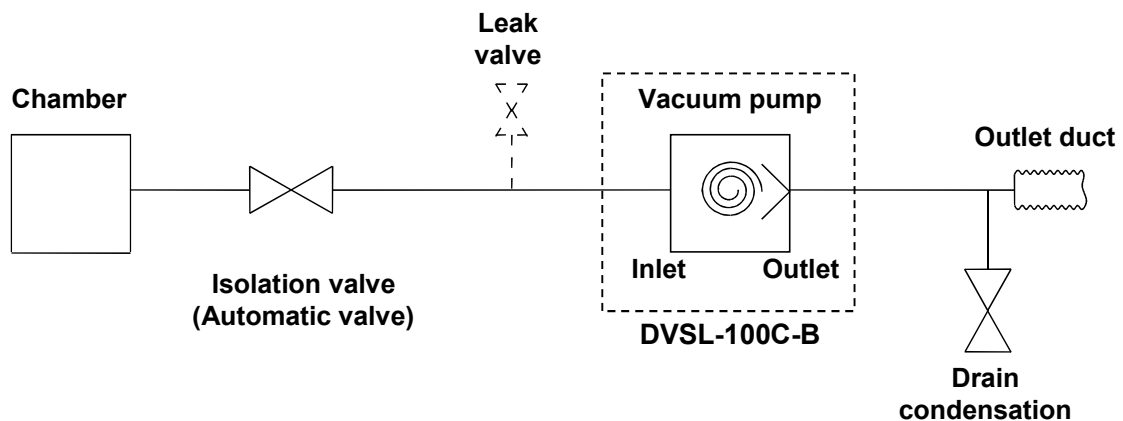





It causes exhaust disturbance. Drain condensations periodically by using valve separately arranged.



# 4. Operation

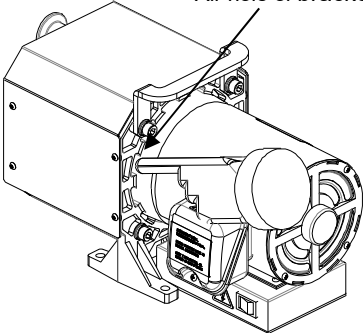





Be sure to use the procedure below to start up or shut down the pump.

- When you do not use air-flush device, **proceed 4.1 Standard operation [page 20].**
- When you use air-flush device, **proceed 4.2 Air-flush operation [page 21].**

 <b>WARNING</b>	
<p><b>Danger of explosion and ignition</b></p> <p><b>Do not evacuate gas which is hazardous to humans or explosive, flammable, or corrosive. Do not evacuate with substances containing chemicals, solvents, and powders.</b></p> <p>If done, it can cause failure or bodily injury by gas, explosion or ignition.</p> <div style="border: 1px solid black; padding: 5px; margin: 10px 0;"> <p style="text-align: center;"> <b>Do not pump</b></p> <ul style="list-style-type: none"> <li>· Toxic gas</li> <li>· Explosive gas</li> <li>· Flammable gas</li> <li>· Corrosive gas</li> <li>· Chemicals</li> <li>· Solvent</li> <li>· Powder</li> <li>· Water</li> <li>· Liquid</li> </ul> </div> <p>※When evacuating vapor, operate in accordance with 4.2 [page 21].            ※Fluorine rubber seal specification can be used for exhaust some solvents.            However It is not guaranteed fluorine rubber can be used for all solvents.</p>	 <b>Never evacuate hazardous gas</b>
<p><b>Danger of entanglement and foreign matter dispersal</b></p> <p><b>Never put finger or foreign matter into air holes of bracket.</b></p> <p>If done, it can cause bodily injury from entanglement with turning section, or foreign matter dispersal.</p> <div style="text-align: center; margin: 10px 0;">   <b>Finger, foreign matter</b>            Air hole of bracket         </div> 	 <b>Avoid foreign matter</b>
<p><b>Danger of electric shock and entanglement</b></p> <p><b>Do not remove or alter safeguards or insulation parts.</b></p> <p>If done, it can cause bodily injury from electric shock or turning section and it can cause deteriorated performance and operating lifetime, and invalidate guarantee.</p>	 <b>Never alter</b>
<p><b>Danger of failure and bodily injury</b></p> <p><b>Change air-flush port only after vacuum pump is stopped.</b></p> <p>If you change it during vacuum pump operation, it can cause vacuum pump failure and bodily injury.</p>	 <b>Change after vacuum pump is stopped</b>



## CAUTION

<p><b>Danger of vacuum break and pollution</b></p> <p><b>Be sure to close isolation valve between vacuum pump and vacuum system (chamber) during start-up and stop.</b> Start-up or stop with isolation valve in the open position can draw back gas and debris attached to inside of vacuum pump to vacuum chamber due to pressure differential, resulting in vacuum break and pollution on vacuum chamber side.</p>	 <b>Start or stop after closing isolation valve</b>
<p><b>Danger of exceeding permissible temperature of intake gas</b></p> <p><b>If intake gas temperature is over 50°C, be sure to install a chiller or trap between vacuum pump and vacuum chamber so that gas intake temperature of vacuum pump keeps below 50°C.</b> If not, vacuum pump temperature can increase, resulting in failure.</p>	 <b>Beware temperature of intake gas</b>
<p><b>Danger of remaining moisture</b></p> <p><b>When evacuating moisture, be sure to open air-flush port (air-flush operation).</b> If you evacuate vapor while air-flush port is closed, condensed water will remain inside vacuum pump and cause failure.</p>	 <b>Operate while opening air-flush port</b>
<p><b>Danger of insufficient vapor exhaust</b></p> <p><b>After evacuating vapor, do air-flush operation for at least one hour.</b> If you close air-flush port or stop vacuum pump soon after evacuating vapor, condensed moisture will remain inside vacuum pump, which will cause failure.</p>	 <b>Caution after exhausting vapor</b>
<p><b>Danger of exceeding permissible intake gas volume</b></p> <p><b>When sending N<sub>2</sub> gas or dry air into air-flush port, pressure should be the same as atmospheric pressure and flow rate should be less than 5L/min.</b> If not, it can increase pressure inside vacuum pump, resulting in failure.</p>	 <b>Beware of intake gas volume</b>
<p><b>Risk of motor malfunction</b></p> <p><b>Refrain from frequent start/stop operation.</b> It induces malfunction of motor such as burn out. Please consult your dealer or factory representative for details. Appropriate operating mode with adequate interval and frequency of start/stop is varies owing to operating condition.</p>	 <b>Caution for frequent start/stop and short interval</b>

## Important

**If it takes time to reach ultimate pressure of pump during initial operation (also operation after pump has not been used for a long time),**

Close inlet, and continue operation for 6~8 hours while opening inlet for 3~5 seconds to atmosphere 2~3 times per hour. During pump stoppage, moisture might have entered inside of pump and deteriorated performance to reach ultimate pressure.

**If pump has evacuated liquid such as water or high humid air (over 60%RH),**

Moisture can deposit inside pump and cause pump failure. In that case, close isolation valve, and open inlet to atmosphere for 3~5 seconds several times and exhaust moisture inside pump to outside.

**If pump has continued operation around ultimate pressure or continuously evacuated high humid gas**

Moisture can be condensed and remains inside pump, causing insufficient ultimate pressure and failure.

In that case, do air-flush operation in accordance with 4.2 [page 21].

## 4.1 Standard operation

### 4.1.1 Start-up

- ① Check that caps of inlet and outlet is removed.
- ② Close isolation valve in order to prevent the drawback of debris attached to the inside of vacuum pump into vacuum chamber due to pressure differential, resulting in vacuum break and pollution.  
(Open leak valve if you use leak valve).
- ③ Turn on vacuum pump.  
Please install an external power switch or protective device (breaker) before letting vacuum pump operate.
- ④ Check start-up of vacuum pump and open isolation valve (close leak valve soon after start-up if you use leak valve) and evacuate vacuum chamber.

### Important

**When continuously operating pump at around ultimate pressure,  
(for example, using as fore line pump of turbo molecular pump)**

It can cause foreign matter or moisture to deposit inside pump, resulting in failure.

In that case, do air-flush operation or close isolation valve and open inlet to atmosphere for 3~5 seconds, 3~5 times daily.

**Be careful not to damage air-flush port (especially air-muffler section).**

If not, it can cause failure.

**When doing air-flush operation,**

Noise level will increase (by 5dB).

**Install pump in an area which is not exposed to debris such as iron powder, stone powder, polish powder or wood dust.**

Debris can clog air-muffler, undercutting air-flush effect.

### 4.1.2 Shut-down

- ① Be sure to close isolation valve in order to prevent the drawback of debris attached to inside of vacuum pump into vacuum chamber during operation due to pressure differential (open leak valve if you use leak valve).
- ② Turn off vacuum pump.  
Please install an external power switch or protective device (breaker) before letting vacuum pump operate.
- ③ Check shut-down of vacuum pump.

### Important

**Be sure to close isolation valve between vacuum pump and vacuum chamber during pump shut-down.**

If vacuum pump stops during air-flush operation, atmospheric air is drawn back from air-flush port to inside of vacuum pump, and vacuum on chamber side cannot be maintained. Be sure to close isolation valve between vacuum pump and vacuum chamber to prevent the drawback of debris from vacuum pump into vacuum chamber before stopping vacuum pump.

When returning air-flush operation to standard operation, operate as per 4.2.3[page 22].

## 4.2 Air-flush operation

This pump is equipped with air-flush port. Before evacuating vapor, read precautions below completely and be sure to understand the contents.

### Purpose of air-flush

Processing humid air by vacuum pump may cause condensed water to remain in pump. This remaining condensation will cause a failure of ultimate pressure of pump. Air-flush operation will contribute to remove the remaining condensation inside. Air-flush operation does not only removing condensation but also restores ultimate pressure.

※Continuous operation with the air flush function does not affect performance of the vacuum pump.  
※Vapor disposal volume is max. 100g/day when doing air-flush operation(ambient temperature 25°C, humidity 60%RH).

## Important

**Maintenance interval of this pump is based on clean gas applications The standard differs when evacuating vapor.**

You must shorten maintenance interval (5.2[page 24]) when evacuating vapor since vapor temperature, disposal volume, disposal frequency and substances in vapor have an influence on pump operation. When evacuating vapor, pay attention to all WARNING, CAUTION and Important notes (4 [page 18~19]).

### 4.2.1 Preparation

Before starting air-flush operation, first stop vacuum pump and proceed in accordance with the following procedure. Never try to do air-flush operation during operation.

### Fit air-muffler

- ① Stop vacuum pump.
- ② Remove plug from air-flush port with a spanner (nominal dia. 7mm).
- ③ Lightly fit the attached air-muffler to air-flush port.

※Store the removed plug and do not misplace it.

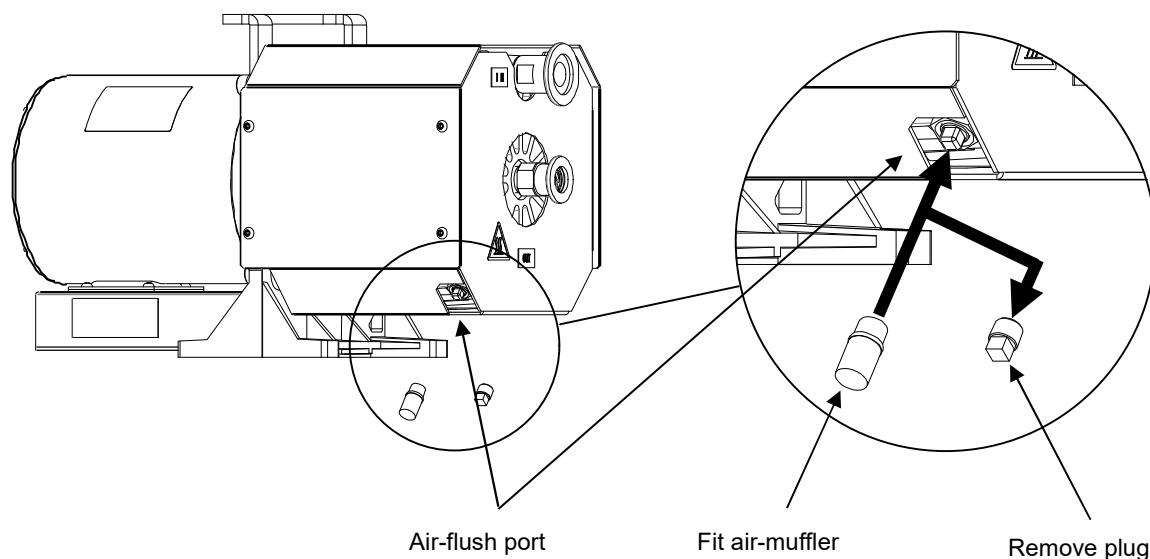

## 4.2.2 Start-up and shut-down

- ① Start vacuum pump according to 4.1.1 Operation [page 20].
- ② Stop vacuum pump according to 4.1.2 Shut-down [page 20].

### Important

#### Continuous evacuating of humid gas

When evacuating vacuum chamber while humidity in chamber is high, moisture volume drawn into pump differs according to temperature and pressure in chamber.

When pumping vacuum chamber containing humid gas, be sure to open air-flush port and operate pump (air-flush operation).

#### Be careful not to damage air-flush port (especially air-muffler section).

Damage to air-flush port can cause failure.

#### When doing air-flush operation

Noise level will increase (by 3dB).

#### Install pump in an area which is not exposed to debris such as iron powder, stone powder, polish powder or wood dust.

Debris can clog air-muffler, undercutting air-flush effect.

#### Be sure to close isolation valve between vacuum pump and vacuum chamber during pump shut-down.

If vacuum pump stops during air-flush operation, atmospheric air is drawn back from air-flush port to inside of vacuum pump, and vacuum on chamber side cannot be maintained. Be sure to close isolation valve between vacuum pump and vacuum chamber to prevent the drawback of debris from vacuum pump into vacuum chamber before stopping vacuum pump.

When operating with air-flush OFF (closed), operate as per 4.2.3 [page 22].

## 4.2.3 When returning to standard operation

Before starting air-flush operation, first stop vacuum pump and proceed in accordance with the following procedure. Never perform this procedure during operation.





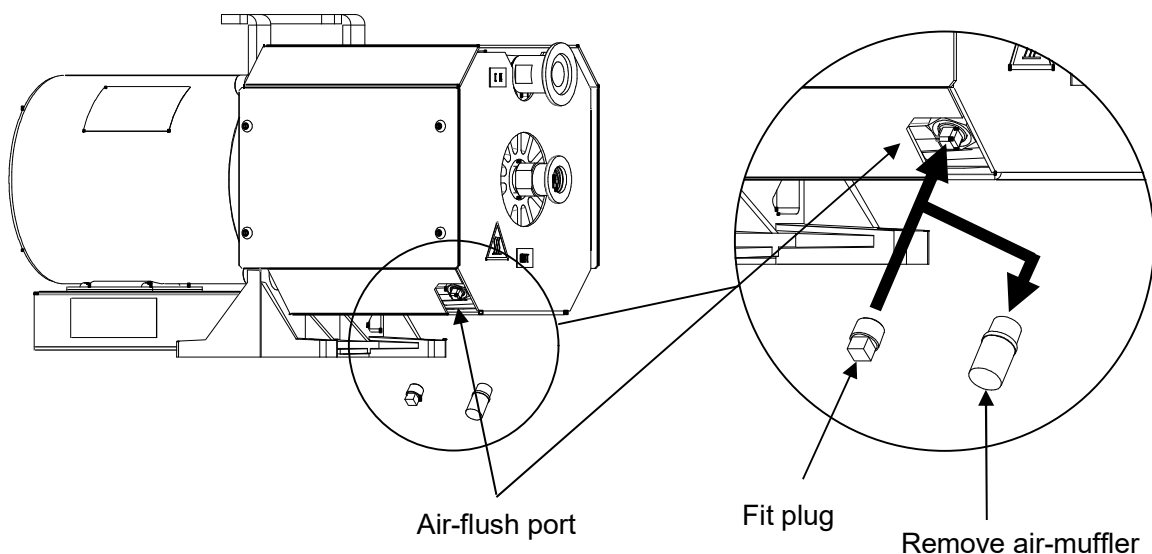

### Remove air-muffler

- ① Stop vacuum pump.
  - ② Remove air-muffler from air-flush port.
  - ③ Lightly fit plug to air-flush port with a spanner (nominal dia. 7mm).
- ※When restarting air-flush operation, refer to 4.2.1~4.2.2 [page 21~22] and prepare and start.
- ※Store removed air-muffler and pay attention not to misplace it.





## 5. Maintenance and inspection

 <b>WARNING</b>	
<p><b>Danger of failure and bodily injury</b></p> <p><b>Conduct periodical maintenance and inspection.</b> If not, it can cause insufficient performance, failure of vacuum pump, and bodily injury.</p>	 <b>Conduct periodical maintenance and inspection</b>
<p><b>Danger of burns</b></p> <p><b>Conduct maintenance and inspection only after vacuum pump becomes cool enough.</b> Maintenance and inspection soon after vacuum pump stops can cause burn injury.</p>	 <b>Be careful about high temperature</b>
<p><b>Danger of restart</b></p> <p><b>Be sure to switch off electric source before maintenance or inspection. Single-phase motor has a thermal protector.</b> Vacuum pump restarts become cool without warning after vacuum pump.</p>	 <b>With a thermal protector</b>
<p><b>Danger of electric shock</b></p> <p><b>Be sure to conduct maintenance and inspection after you turn off electric source.</b> If not, it can cause bodily injury from electric shock or turning object.</p>	 <b>Turn off electric source</b>
<p><b>Danger of accident, failure and shorter operating lifetime</b></p> <p><b>Ask specialist to perform repairs.</b> Defective repairs can cause accident, failure or shorter operating lifetime.</p>	 <b>Ask specialist to perform repairs</b>

### 5.1 Daily maintenance and inspection

Conduct daily the following maintenance and inspection procedures.

Items	Contents	Measures
Vacuum pump itself	Abnormal sound	Ask specialist to repair.
	Abnormal vibration	Ask specialist to repair.
	Abnormal temperature	Ask specialist to repair.
	Cooling fins are dirty or clogged	Blowing air, cleaning
Air-muffler	Dirty, clogged	Replace
Exhaust valve	Dirty, clogged	Blowing air, clean
Electric source cable	Deteriorated	Replace

## 5.2 Maintenance

When maintenance interval has elapsed, be sure to contact our dealer who sold it to you. This vacuum pump requires maintenance conducted only by our authorized specialist.

Never try to disassemble, reassemble or alter on user's side. We are not responsible for any accidents caused by disassembly, reassembly or alteration which was done by the user or non-specialist.

The following parts are consumable and need to be replaced periodically. Whenever something goes wrong with them, replace them immediately.

Where to inspect	Maintenance interval			
	Yearly or 8,000 h	Biennially or 16,000 h	Triennially or 24,000 h	4th years or 32,000 h
Angular contact Ball bearing set	-	Grease / Δ	-	○
Pin crank set	Grease / Δ	Grease / Δ	Grease / Δ	○
Duplex arrangement angular ball bearing set [Housing]	-	Grease / Δ	-	○
Roller bearing set [OS]	Grease / Δ	Grease / Δ	Grease / Δ	○
Spider	○	○	○	○
P-seal [FS set]	○	○	○	○
Tip seal FS	○	○	○	○
Tip seal OS	○	○	○	○
Air-flush kit	○	○	○	○
Cooling fan	Δ	Δ	Δ	○
Vacuum pump itself	-	-	-	○

○ . . . Replace

Δ . . . Replace if something goes wrong.

Note 1 : Be sure to use designated DVSL exclusive grease.

Note 2 : You must shorten maintenance standard when pumping vapor since vapor temperature , disposal volume, disposal frequency and substances in vapor have influence on pump operation.

Note 3 : The maintenance interval should be earlier one in either the period or running hours.

Note 2 : When you want further operation after either the 4<sup>th</sup> year or 32,000 operating hours, please contact our dealer who sold it to you.

### Important

#### Causes of failure

Shorten maintenance interval if conditions of installation or operation are unfavorable.

In particular, ambient temperature has a great influence on failure. Maintenance interval is based on an ambient temperature 5~40°C and a yearly average ambient temperature 25°C.

Shorten the maintenance interval if temperature exceeds the foregoing. If not, it can cause failure.

**Maintenance interval is not a guarantee period.**

#### Exceeding maintenance interval

Operation exceeding maintenance interval increases risk of failure and accidents.

When maintenance interval has elapsed, be sure to contact either the dealer who sold it to you or us.

## 6. Problems and remedies

If something goes wrong, refer to the following chart and remedy problems.

If you cannot solve your problems, please contact either our dealer who sold it to you or us.

Problems	Causes	Remedies
<b>Motor does not rotate.</b>	Protective device (or breaker) activates.	Check protective device (or breaker) capacity. ※Inspect and repair.
	Electric source cable is loose or cut.	Check connection. Repair or replace.
	Voltage drops.	Check size and length of cable.
	Motor malfunctions.	※Inspect and repair.
	Pump malfunctions. Foreign matter enters.	※Inspect and repair.
	Motor protection gear activates.	Air outlet is clogged. ※Inspect and repair.
<b>Motor stops soon.</b>	Protective device (or breaker) activates.	Check protective device (or breaker) capacity. ※Inspect and repair.
	Voltage drops.	Check size and length of cable.
	Motor malfunctions.	※Inspect and repair.
	Pump malfunctions. Foreign matter enters.	※Inspect and repair.
	Improper exhaust piping.	Check exhaust piping diameter and length. Air outlet is clogged.
	Motor protection gear activates.	Air outlet is clogged. ※Inspect and repair.
<b>Ultimate pressure is insufficient.</b>	Air leaks from piping. O-ring is damaged.	Check tightness of piping. Replace.
	Moisture and solvent are drawn.	Open inlet to atmosphere and operate for a few minutes and then close inlet and operate for about 24 hours. Do air-flush operation. Install trap and filter.
	Number of motor revolutions drops.	Check wiring and voltage. ※Inspect and repair.
	Pump malfunctions.	※Inspect and repair.
<b>Abnormal sound, abnormal vibration</b>	Connection becomes loose.	Tighten connection. ※Inspect and repair.
	The fix is not level.	Fix vacuum pump on solid and level floor (less than 5° inclination). ※Inspect and repair.
	Foreign matter enters pump.	※Inspect and repair.
	Motor malfunctions.	※Inspect and repair.
	Pump malfunctions.	※Inspect and repair.

※ Contact our dealer who sold it to you.

## 7. Disposal

When a vacuum pump is disposed, please comply with local law and/or regulations such as the Waste Disposal Law.

# 8. Specifications

## 8.1 Specifications

Model		DVSL-100C-B				
Back-up material		Fluorine rubber				
Displacement L/min	50Hz	100				
	60Hz	120				
Ultimate pressure Pa		≤ 50				
Max. inlet pressure		Atmospheric pressure				
Ambient operating temperature °C		5~40				
Motor	Type	Single-phase induction motor 2P, Totally-enclosed, Insulation Class B, Capacitor start, run, Thermal Protector TP212, Automatic reset type				
	Output kW	0.3				
	Voltage V	100	115	200	230	
	Rated current A	50Hz	2.6	—	1.3	1.4
		60Hz	2.9	2.8	1.6	1.4
	Revolution min <sup>-1</sup> {rpm}	50Hz	2925	—	2925	2940
		60Hz	3490	3520	3490	3520
Noise emission value Sound pressure level dB(A)	1m	≤ 62 ( With air-flush ON: ≤ 65 )				
	Surface	64 ( Uncertainty:3 )				
Inlet connection		NW25 [Internal screw size : Rc3/8]				
Outlet connection		NW16 [With exhaust valve]				
Dimensions mm L×W×H		380×221×218				
Mass kg		17				
Cooling system		Air-cooled				
Others		With air-flush				

Note 1 : Fluorine rubber used in this product may not be compatible for certain chemicals.

Please contact chemical supplier.

Note 2 : Pumping speed and ultimate pressure should remain the same whether air-flush system is used or not.

Note 3 : Maximum voltage allowance is + or - 10% from motor rating.

Note 4 : Noise emission value is measured at ultimate pressure.

Note 5 : Noise emission value (1m) is measured at 1m from the product surface in an anechoic room.

Note 6 : Noise emission value (Surface) determined according to noise test code given in ISO 3744 and according described to ISO 4871. The sum of a measured noise emission value and its associated uncertainty represents an upper boundary of the range of values which is likely to occur in measurements.

Note 7 : Vapor handling volume is no more than 100g/day (at 25°C 60%RH) with air-flush operation.

Air-flush flow rate is 5L/min.

Note 8 : This product is wired for 100V at the factory.

Note 9 : Install circuit protection device for safety. Consult to qualified electrician for details.

Note 10 : This product is designed for indoor use. Install the product away from moistures or excessive humidity.

Note 11 : All data shown in this literature were measured based on our test standard and specific conditions.

Actual measurements are subject to change of conditions of use.

Note 12 : ANEST IWATA reserves the right to change descriptions or specifications in this literature without prior notice.

## 8.2 Dimensions

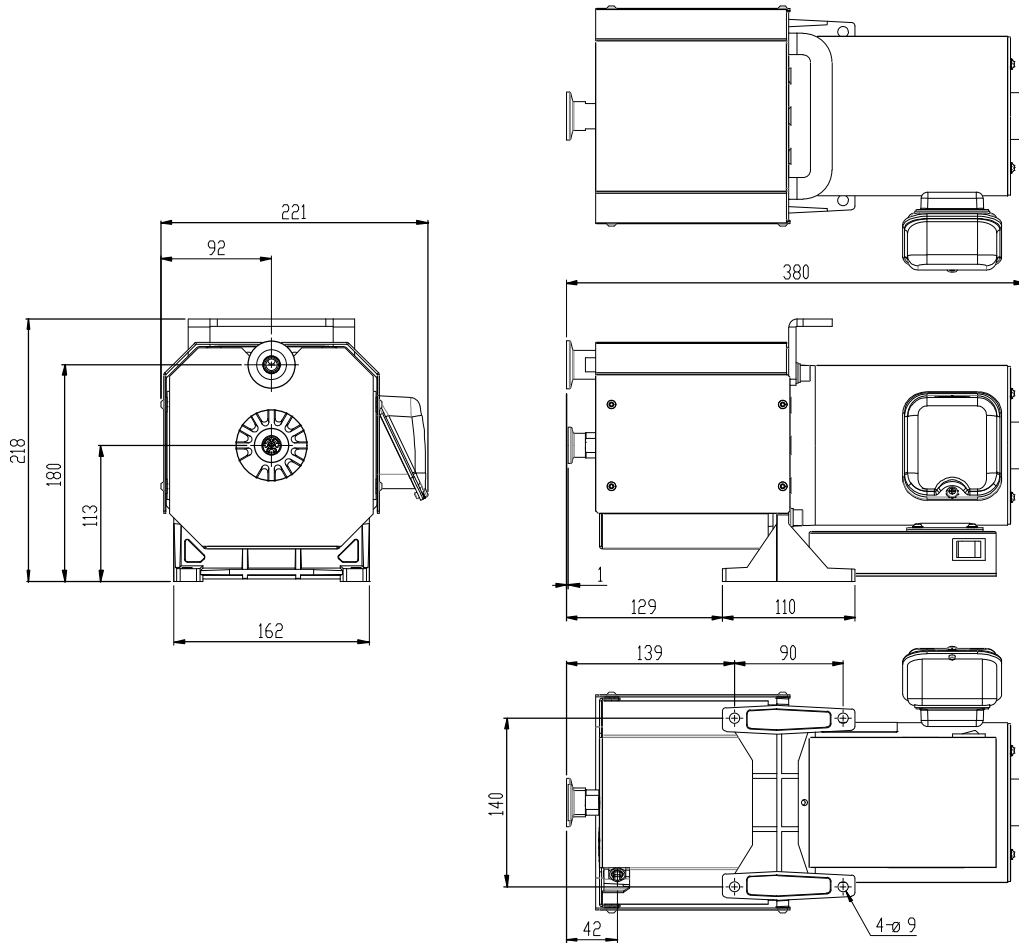

## 8.3 Performance data

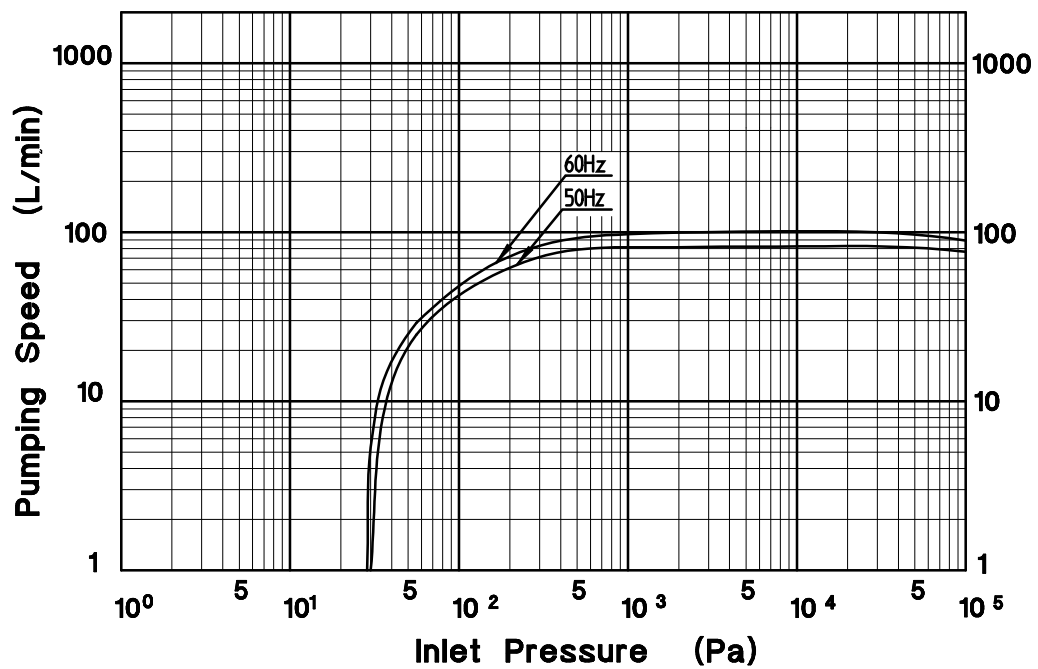

# Memo



Manufacturer

 **ANEST IWATA Corporation**

3176, Shinyoshida-cho, Kohoku-Ku,  
Yokohama 223-8501, Japan  
Tel +81 (0) 45-591-1112  
Fax +81 (0) 45-591-1539  
<http://www.anest-iwata.co.jp/>

European agent

 **ANEST IWATA Europe GmbH**

Am Stahlbügel 2,  
74206 Bad Wimpfen, Germany  
Tel +49-7063-93-3670  
<http://www.anest-iwataat.com>

Manual No.V200-01  
Code No.08821691